

# *Operating Instruction*

Original Operating Instructions

**DR6X**

**Rammer**



S/N 101 924 01 1001> / S/N 101 924 02 1001>  
DL8 203 62 EN  
© 06/2018



## Table of contents

<b>1</b>	<b>Introduction</b> .....	<b>7</b>
	<b>1.1 Foreword</b> .....	<b>8</b>
	<b>1.2 Machine type plate and engine type plate</b> .....	<b>10</b>
<b>2</b>	<b>Technical data</b> .....	<b>11</b>
	<b>2.1 Noise and vibration data</b> .....	<b>13</b>
	2.1.1 Noise data.....	13
	2.1.2 Vibration data.....	14
<b>3</b>	<b>Concerning your safety</b> .....	<b>15</b>
	<b>3.1 Basic prerequisites</b> .....	<b>16</b>
	3.1.1 General.....	16
	3.1.2 Explanation of signal words used:.....	16
	3.1.3 Personal protective equipment.....	17
	3.1.4 Intended use.....	18
	3.1.5 Improper use.....	18
	<b>3.2 Definition of responsible persons</b> .....	<b>20</b>
	3.2.1 Operating company.....	20
	3.2.2 Expert / qualified person.....	20
	3.2.3 Driver / operator.....	20
	<b>3.3 Basic safety regulations for safe operation</b> .....	<b>22</b>
	3.3.1 Remaining dangers, remaining risks.....	22
	3.3.2 Regular safety inspections.....	22
	3.3.3 Modifications and alterations to the machine.....	22
	3.3.4 Damage, defects, misuse of safety devices.....	22
	<b>3.4 Handling fuels and lubricants</b> .....	<b>23</b>
	3.4.1 Preliminary remarks.....	23
	3.4.2 Safety regulations and environmental protection regulations for handling oil.....	24
	3.4.3 Safety regulations and environmental protection regulations for handling gasoline.....	25
	3.4.4 Safety regulations and environmental protection regulations for handling fuel stabiliser.....	26
	<b>3.5 Loading/transporting the machine</b> .....	<b>27</b>
	<b>3.6 Start up procedure</b> .....	<b>28</b>
	3.6.1 Prior to starting up.....	28
	3.6.2 Starting the engine.....	28
	<b>3.7 Operation</b> .....	<b>29</b>
	3.7.1 Persons in the danger area.....	29
	3.7.2 Operation.....	29
	3.7.3 Parking the machine.....	29
	<b>3.8 Refuelling</b> .....	<b>30</b>
	<b>3.9 Maintenance work</b> .....	<b>31</b>
	3.9.1 Preliminary remarks.....	31
	3.9.2 Working on the engine.....	31
	3.9.3 Working on the tamper foot.....	31
	3.9.4 Cleaning work.....	31
	3.9.5 After maintenance work.....	31
	<b>3.10 Repair</b> .....	<b>32</b>

## Table of contents

3.11	Signage.....	33
4	Indicators and control elements.....	37
5	Checks prior to start up.....	39
5.1	Notes on safety.....	40
5.2	Visual inspections and function tests.....	41
5.3	Checking the engine oil level.....	42
5.4	Checking the fuel level; topping up fuel.....	43
5.5	Checking the rubber buffers.....	44
6	Operation.....	45
6.1	Adjusting the guide handle.....	46
6.2	Starting the engine.....	47
6.3	Operation.....	51
6.4	Parking the machine in secured condition.....	53
6.5	Operating hour meter/engine rpm-meter.....	54
7	Loading/transporting the machine.....	57
7.1	Loading the machine.....	58
7.2	Lashing the machine to the transport vehicle.....	60
8	Maintenance.....	61
8.1	Preliminary remarks and safety notes.....	62
8.2	Fuels and lubricants.....	63
8.2.1	Engine oil.....	63
8.2.2	Fuel.....	63
8.2.3	Gear oil SAE 75W-90.....	64
8.3	List of fuels and lubricants.....	65
8.4	Running-in instructions.....	66
8.4.1	General.....	66
8.4.2	After 25 operating hours.....	66
8.5	Maintenance Table.....	67
8.6	Weekly.....	68
8.6.1	Checking, cleaning the air filter.....	68
8.7	Monthly.....	71
8.7.1	Checking the tamper foot.....	71
8.8	Semi-annually.....	73
8.8.1	Changing the engine oil.....	73
8.9	Annually.....	74
8.9.1	Checking, adjusting the valve clearance.....	74
8.9.2	Replacing the spark plug.....	79
8.9.3	Replacing the fuel filter.....	80
8.9.4	Cleaning the fuel screen.....	83
8.9.5	Replacing the air filter.....	85
8.9.6	Checking, adjusting the engine speed.....	87
8.9.7	Replacing the starter rope.....	90
8.9.8	Changing the oil in the rammer foot.....	92
8.10	As required.....	94
8.10.1	Cleaning the machine.....	94

8.10.2	Checking, cleaning the spark plug.....	94
<b>9</b>	<b>Setting up / refitting.....</b>	<b>97</b>
9.1	Changing the tamper foot plate.....	98
<b>10</b>	<b>Troubleshooting.....</b>	<b>99</b>
10.1	Preliminary remarks.....	100
10.2	Engine faults.....	101
10.3	What to do if the engine has flooded.....	103
<b>11</b>	<b>Disposal.....</b>	<b>107</b>
11.1	Final shut-down of machine.....	108





### 1.1 Foreword

These operating and maintenance instructions are part of your machine.

They provide necessary information to operate your machine safely and properly.

They also contain information on required operating, maintenance and repair measures.

Carefully read the operating and maintenance instructions before taking your machine into operation.

Please observe the safety regulations strictly and follow all instructions to ensure safe operation.

If you are not yet acquainted with the indicators and control elements on this machine, you should thoroughly read the corresponding chapter ↪ *Chapter 4 „Indicators and control elements“ on page 37.*

The description of the individual operating steps including the notes on safety to be followed can be found in chapter “Operation” ↪ *Chapter 6 „Operation“ on page 45.*

Before every start up, carry out all required visual inspections and function tests ↪ *Chapter 5 „Checks prior to start up“ on page 39.*

Ensure the compliance with the specified operating, maintenance and repair measures to maintain the functional safety of your machine.

A description of all necessary maintenance work, maintenance intervals as well as information on fuels and lubricants can be found in the chapter “Maintenance” ↪ *Chapter 8 „Maintenance“ on page 61.*

Do not service or repair your machine by yourself to avoid harming persons or damaging material or environment.

The machine must only be serviced and repaired by qualified and authorised personnel.

Contact our customer service to carry out the required maintenance work or necessary repairs.

In case of operating errors, inadequate maintenance or the use of unapproved fuels and lubricants all warranty claims will become null and void.

For your own personal safety you should only use original parts from Dynapac.

For your machine we offer service kits to make maintenance easier.

In the course of technical development we reserve the right for technical modifications without prior notification.

These operating and maintenance instructions are also available in other languages.

Apart from that, you can also order the spare parts catalogue against the serial number of your machine.

The above notes do not constitute an extension of the warranty and liability conditions specified in the general sales and delivery conditions of Dynapac GmbH.

We wish you successful work with your Dynapac machine.

**1.2 Machine type plate and engine type plate**

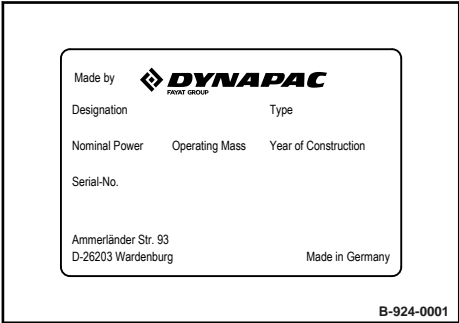

*Fig. 1: Machine type plate (example)*

<b>Please enter here:</b>	
Machine type (1):	
Serial number (2):	

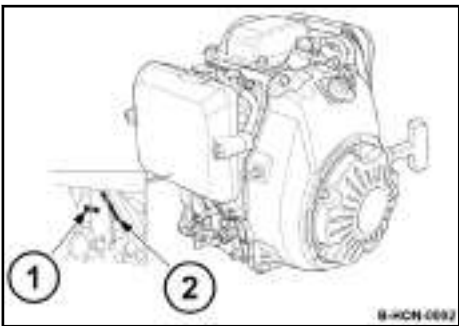

*Fig. 2: Engine type and engine number*

<b>Please enter here:</b>	
Engine type (1):	
Engine number (2):	



## Technical data

### Dimensions

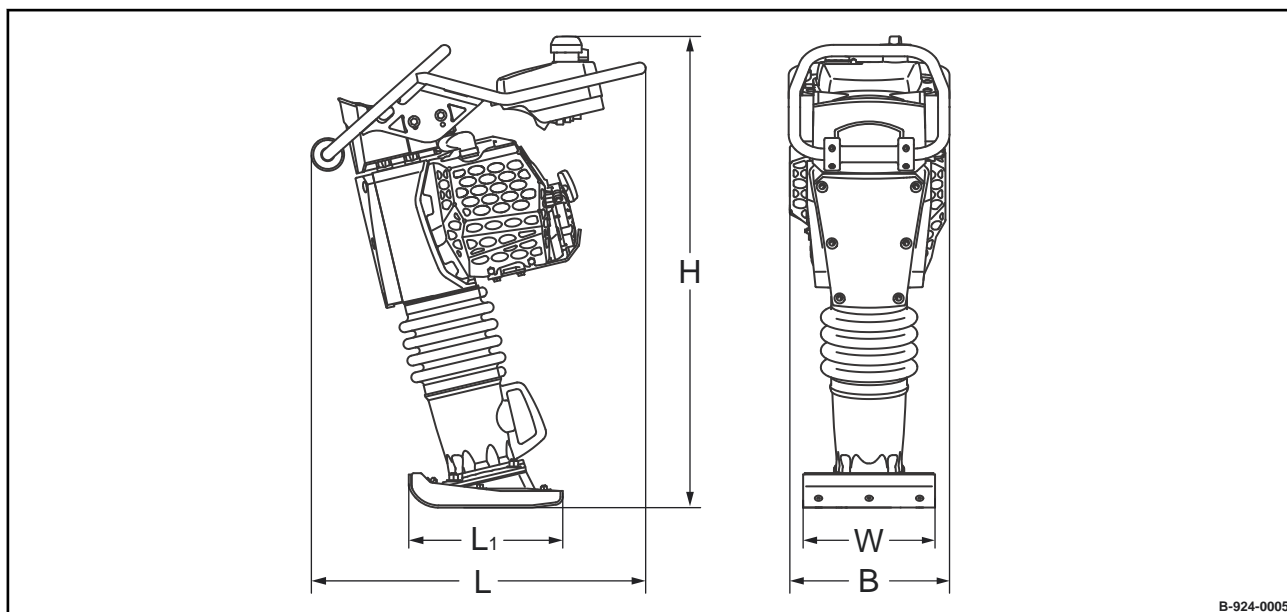

B-924-0005

Fig. 3

B	H	L	L <sub>1</sub>	W
350 (13.8)	1030 (40.6)	728 (28.7)	335 (13.2)	230 (9.1)
Dimensions in millimetres (Dimensions in inch)				

Weights		
Basic weight	57 (126)	kg (lbs)
Operating weight (CECE)	58 (128)	kg (lbs)

Travel characteristics		
Max. working speed	20 (66)	m/min (ft/min)
Max. area output (depending on soil)	276 (2971)	m <sup>2</sup> /h (ft <sup>2</sup> /h)

## Technical data – Noise and vibration data

Drive		
Engine manufacturer	Honda	
Type	GXR 120	
Cooling	Air	
Number of cylinders	1	
Displacement	121	cm <sup>3</sup>
Rated power SAE J 1349	2.8	kW
	(3.8)	(hp)
Rated speed	4200	min <sup>-1</sup>

Exciter system		
Drive system	mechanical	
Frequency	10 - 11.8	Hz
	(600 - 708)	(bpm)
Impact force	15	kN
	(3372)	(lbf)

Filling capacities		
Fuel (gasoline)	3.0	l
	(0.8)	(gal us)

## 2.1 Noise and vibration data

The following noise and vibration data were determined in accordance with the following guidelines under equipment specific conditions and by using harmonized standards:

- EU Machine Directive edition 2006/42/EU
- Noise Emission Directive 2000/14/EU, Noise Protection Directive 2003/10/EU
- Vibration Protection Directive 2002/44/EU

During operation these values may vary because of the prevailing operating conditions.

### 2.1.1 Noise data

**Sound pressure level at the operator's stand**

$L_{pA} = 93 \text{ dB(A)}$ , determined acc. to ISO 11201 and EN 500.

## Technical data – Noise and vibration data



### WARNING!

Loss of hearing caused by too high noise burdens!

- Wear your personal protective equipment (ear protection).

### Guaranteed sound power level

$L_{WA} = 108 \text{ dB(A)}$ , determined acc. to ISO 3744 and EN 500.

## 2.1.2 Vibration data

### Hand-arm vibration

Vector total of the weighted effective acceleration in three orthogonal directions:

**Total vibration value  $a_{hv} = 4.8 \text{ m/s}^2$**  on crushed rock determined acc. to EN 500/ISO 5349.

**Associated uncertainty  $K = 0.7 \text{ m/s}^2$** , determined acc. to EN 12096.

Observe the daily vibration load (work safety acc. to 2002/44/EC).



### 3.1 Basic prerequisites

#### 3.1.1 General

This machine has been built in compliance with the latest technical standard and complies with the applicable regulations and technical rules.

However, dangers for persons and property may arise from this machine, if:

- it is used for purposes other than the ones it is intended for,
- it is operated by untrained personnel,
- it is changed or converted in an unprofessional way,
- the safety instructions are not observed.

Each person involved in the operation, maintenance and repair of the machine must therefore read and comply with these safety regulations. If necessary, the operating company must obtain the relevant signatures as confirmation.

Furthermore, the following obviously also applies:

- applicable accident prevention instructions,
- generally accepted safety and road traffic regulations,
- country/state specific safety regulations.

It is the duty of the operator to be acquainted with the safety regulations and to apply these accordingly. This also applies for local regulations and regulations concerning different types of handling activities. Should the recommendations in these instructions be different from the regulations valid in your country, you must comply with the safety regulations valid in your country.

#### 3.1.2 Explanation of signal words used:



##### **DANGER!**

##### **Danger to life if failing to comply!**

Sections marked accordingly indicate an extremely dangerous situation that could lead to fatal or severe injuries, if this warning is disregarded.



##### **WARNING!**

##### **Danger to life or danger of severe injuries if failing to comply!**

Sections marked accordingly indicate a dangerous situation that could lead to fatal or severe injuries, if this warning is disregarded.

## Concerning your safety – Basic prerequisites



### CAUTION!

#### Danger of injury if failing to comply!

Sections marked accordingly indicate a dangerous situation that could lead to fatal or severe injuries, if this warning is disregarded.



### NOTICE!

#### Danger of material damage if failing to comply!

Sections marked accordingly indicate possible dangers for machines or components.



*Sections marked accordingly indicate technical information or notes on using the machine or its components.*



### ENVIRONMENT!

#### Environmental damage if failing to comply!





Paragraphs marked accordingly indicate practices for safe and environment-friendly disposal of fuels and lubricants as well as replacement parts.

### 3.1.3 Personal protective equipment

Depending on the work to be carried out, personal protective equipment is required (to be provided by the operating company):

	Working clothes	Tight fitting working clothes with low tear resistance, tight sleeves and without any projecting parts protect against being caught by moving components.
	Safety shoes	To protect against heavy falling parts and slipping on slippery ground.
	Protective gloves	To protect the hands against excoriation, punctures or deep injuries, against irritating and caustic substances as well as against burns.

## Concerning your safety – Basic prerequisites

	Safety goggles	To protect the eyes against airborne particles and squirting fluids.
	Face protection	To protect the face against airborne particles and squirting fluids.
	Hard hat	To protect the head against falling parts and to protect against injuries.
	Hearing protection	To protect hearing against excessive noise.
	Respiratory protection	To protect respiratory tracts against substances or particles.

### 3.1.4 Intended use

This machine must only be used for:

- Compaction of all types of soils
- Repair work on all types of soil
- Paving of walkways
- Work in trenches
- Underfilling and compaction of hard shoulders

Intended use also includes compliance with the specified operating, maintenance and repair measures.

### 3.1.5 Improper use

Dangers may arise from the machine when it is used for purposes other than the one it is intended for.

Any danger caused by improper use is the sole responsibility of the operating company or driver/operator, the manufacturer cannot be made liable.

## Concerning your safety – Basic prerequisites

Examples for improper use are:

- Working in horizontal direction
- Ramming of poles
- Vibrating of paving blocks

It is not permitted to stand on the machine while working.

starting and operation of the machine in explosive environments and in underground mining is prohibited.

### 3.2 Definition of responsible persons

#### 3.2.1 Operating company

The operating company is the natural or juridical person who uses the machine or in who's name the machine is used.

The operating company must make sure that the machine is only used for the purpose it is intended for and in strict compliance with the safety regulations mentioned in these operating and maintenance instructions.

The operating company must determine and assess the danger in its company. It must then take appropriate action to ensure health and safety at work for its employees and point out any remaining dangers.

The operating company must determine whether there are special operational hazards such as a toxic atmosphere or limiting soil conditions. Such conditions require special, additional measures to remove or reduce the hazard.

The operating company must make sure that all users read and understand the information concerning safety.

The operating company is responsible for the planning and professional execution of regular safety inspections.

#### 3.2.2 Expert / qualified person

An expert / qualified person is a person who, based on his/her professional education and experience, has profound knowledge in the field of construction equipment and the machine in question in particular.

This person is acquainted with the applicable governmental industrial safety regulations, accident prevention instructions, guidelines and generally acknowledged technical rules and regulations (standards, directives, technical rules of other member states of the European Union or other contractual states concerning the agreement about the European Economic Area) in as far as is necessary to be able to judge the safe condition of this machine.

#### 3.2.3 Driver / operator

This machine must only be operated by trained, instructed persons entrusted by the operating company aged 18 or more.

Observe your local laws and regulations.

Rights, obligations and rules of conduct for driver or operator:

The driver or operator must:

- be instructed about his rights and obligations,
- wear protective equipment as appropriate for the application,
- have read and understood the operating instructions,

## Concerning your safety – Definition of responsible persons

- have made himself familiar with the operation of the machine,
- be physically and psychologically able to drive and operate the machine.

Persons under the influence of alcohol, medication or drugs are not allowed to operate, service or repair the machine.

Maintenance and repair work requires specific knowledge and must therefore only be performed by trained specialists.

### 3.3 Basic safety regulations for safe operation

#### 3.3.1 Remaining dangers, remaining risks

Despite careful work and compliance with standards and regulations it cannot be ruled out that further dangers may arise when working with and handling the machine.

Both the machine as well as all other system components comply with the currently valid safety regulations. Nevertheless, remaining risks cannot be ruled out completely, even when using the machine for the purpose it is intended for and following all information given in the operating instructions.

A remaining risk can also not be excluded beyond the actual danger zone of the machine. Persons remaining in this area must pay particular attention to the machine, so that they can react immediately in case of a possible malfunction, an incident or failure etc.

All persons remaining in the area of the machine must be informed about the dangers that arise from the operation of the machine.

#### 3.3.2 Regular safety inspections

Have the machine inspected by an expert / qualified person as required for the conditions the machine is working under, but at least once every year.

#### 3.3.3 Modifications and alterations to the machine

Unauthorized changes to the machine are prohibited for safety reasons.

Original parts and accessories have been specially designed for this machine.

We wish to make explicitly clear that we have not tested or approved any parts or accessories not supplied by us.

The installation and/or use of such products may have an adverse effect on the active and/or passive safety.

#### 3.3.4 Damage, defects, misuse of safety devices

Machines which are not safe to operate or in traffic must be immediately taken out of service and shall not be used, until these deficiencies have been properly rectified.

Safety installations and switches must neither be removed nor must they be made ineffective.

### 3.4 Handling fuels and lubricants

#### 3.4.1 Preliminary remarks

The operating company must ensure that all professional users have read and follow the corresponding safety data sheets for the individual fuels and lubricants.

Safety data sheets provide valuable information about the following characteristics:

- name of substance
- possible dangers
- composition / information on constituents
- first-aid measures
- fire fighting measures
- measures in case of accidental release
- handling and storage
- limitation and monitoring of exposure / personal protective equipment
- physical and chemical properties
- stability and reactivity
- toxicological data
- environmental data
- notes on waste disposal
- information on transport
- legislation
- other data

### 3.4.2 Safety regulations and environmental protection regulations for handling oil

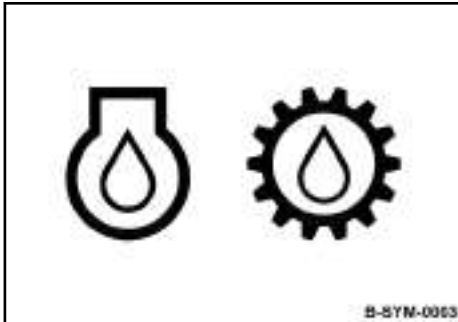

Fig. 4



#### **WARNING!**

##### **Danger of burning by ignited oil!**

- Do not allow oil to come into contact with hot components.
- Smoking and open fire is prohibited!
- Wear your personal protective equipment (protective gloves, protective clothing).



#### **CAUTION!**

##### **Health hazard caused by contact with oil!**

- Wear your personal protective equipment (protective gloves, protective clothing).
- Do not inhale any oil vapours.
- Avoid contact.



#### **CAUTION!**

##### **Danger of slipping on spilled oil!**

- Immediately bind spilled oil with an oil-binding agent.



#### **ENVIRONMENT!**

##### **Oil is an environmentally hazardous substance!**

- Always keep oil in proper containers.
- Immediately bind spilled oil with an oil-binding agent.
- Dispose of oil and oil filter according to regulations.

### 3.4.3 Safety regulations and environmental protection regulations for handling gasoline

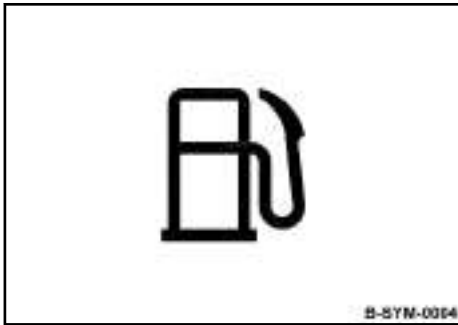

Fig. 5



#### **DANGER!**

**Danger to life caused by explosive gas-air mixes!**

- Do not allow gasoline to come into contact with hot components.
- Smoking and open fire is prohibited.
- Keep away from heat sources, sparks and other sources of ignition.
- Do not spill any gasoline.



#### **WARNING!**

**Health hazard caused by contact with gasoline!**

- Wear your personal protective outfit (protective gloves, protective clothing).
- Do not inhale any fuel fumes.
- Do not swallow gasoline.
- Avoid contact with gasoline.



#### **ENVIRONMENT!**

**Gasoline is an environmentally hazardous substance!**

- Always keep gasoline in proper containers.
- Immediately bind spilled gasoline with an oil-binding agent and dispose of in accordance with regulations.
- Dispose of gasoline and fuel filter according to regulations.

### 3.4.4 Safety regulations and environmental protection regulations for handling fuel stabiliser



#### **WARNING!**

##### **Danger of burning by ignited fuel stabilizer!**

- Do not allow fuel stabilizer to come into contact with hot components.
- Smoking and open fire is prohibited.



#### **WARNING!**

##### **Health hazard caused by contact with fuel stabilizer!**

- Wear your personal protective outfit (protective gloves, protective clothing).
- Do not inhale any fuel stabilizer fumes.
- Do not swallow fuel stabilizer.
- Avoid contact with fuel stabilizer.



#### **ENVIRONMENT!**

##### **Fuel stabilizer is an environmentally hazardous substance!**

- Immediately bind spilled fuel stabilizer with an oil-binding agent and dispose of according to regulations.
- Dispose of fuel stabilizer according to regulations.

### 3.5 Loading/transporting the machine

Make sure that persons are not endangered by the machine tipping or sliding off.

Do not use damaged or in any other way impaired lashing points.

Always use appropriate lifting and lashing means on the lifting and lashing points.

Use lifting and lashing gear only in the prescribed direction of load application.

Lifting tackle must not be damaged by machine components.

Secure the machine on the transport vehicle against rolling, slipping and turning over.

Loads must only be attached and hoisted by an expert / capable person.

Use only lifting gear and lifting tackle with sufficient load bearing capacity for the weight to be loaded.

Fasten the lifting gear only at the specified lifting points.

Danger to the life of persons if they step or stand under a suspended load.

When lifting the machine avoid uncontrolled movements of the load. If necessary hold the load with guide ropes.

### 3.6 Start up procedure

#### 3.6.1 Prior to starting up

Use only machines which are serviced at regular intervals.

Become acquainted with the equipment, the indicators and control elements, the working principle of the machine and the working area.

Use your personal protective equipment (hard hat, safety boots, if necessary also goggles and ear protection).

Do not take any loose objects with you or fasten them to the machine.

Before start up, check whether:

- persons or obstructions are beside or in front of the machine,
- the machine is free of oily and combustible materials,
- all safety elements are in place,
- all grips are free of grease, oils, fuel, dirt, snow and ice.

Before start up, carry out all required visual inspections and function tests.

If the following tests reveal damages or other faults, the machine must not be operated, until these deficiencies have been corrected.

Do not operate the machine with defective indicators and control elements.

#### 3.6.2 Starting the engine

Do not use any starting aids like start pilot or ether.

The machine must not be operated with damaged, missing or non-functional safety installations.

Before starting and moving the machine make sure that there are no persons inside the danger zone.

Keep your feet clear of the tamper foot plate.

Always keep an eye on the machine when the engine is running and hold it by the steering bow.

Do not inhale exhaust fumes, because they contain toxic substances, which could cause damage to health, unconsciousness or even death.

Avoid operation in closed or partly closed rooms, or ensure adequate ventilation when working in trenches.

### 3.7 Operation

#### 3.7.1 Persons in the danger area

Before taking up work, also after breaks, you should always convince yourself that the danger zone is free of persons or obstructions.

Give warning signals, if necessary. Stop work immediately if persons remain in the danger zone, despite the warning.

#### 3.7.2 Operation

Steer the machine only by the steering bow.

Guide the machine so that your hands do not hit against solid objects.

Watch out for unusual noises and development of smoke. Perform trouble shooting and have the fault corrected.

#### 3.7.3 Parking the machine

Park the machine on horizontal, level, firm ground.

Before leaving the machine:

- Shut down the engine,
- Secure the machine against accidental tipping over,
- Secure the machine against unauthorized use.

Mark machines, which could be in the way, with a clearly visible sign.

### 3.8 Refuelling

Do not inhale any fuel fumes.

Refuel only with the engine shut down.

Do not refuel in closed rooms.

No open fire, do not smoke.

Keep away from ignition and heat sources.

Apply measures against electrostatic charging.

Do not spill any fuel. Catch running out fuel, do not let it seep into the ground.

Wipe off spilled fuel. Keep dirt and water away from the fuel.

A leaking fuel tank can cause an explosion. Ensure tight fit of the fuel tank cover, if necessary replace immediately.

### 3.9 Maintenance work

#### 3.9.1 Preliminary remarks

Adhere to the specified operating, maintenance and repair measures.

The machine must only be serviced by qualified personnel authorised by the operating company.

Keep unauthorised persons away from the machine.

Perform maintenance work only with the engine shut down and the spark plug connector disconnected.

Make sure that the engine cannot be accidentally started during maintenance work.

#### 3.9.2 Working on the engine

Drain the engine oil at operating temperature – danger of scalding!

Wipe off spilled oil, catch running out oil and dispose of environmentally.

When working on the air filter no dirt should fall into the air duct.

Do not work on the hot exhaust - danger of burning!

Store used filters and other oil contaminated materials in a separate, specially marked container and dispose of environmentally.

#### 3.9.3 Working on the tamper foot

Drain the tamper foot oil at operating temperature – danger of scalding!

Wipe off spilled oil, catch running out oil and dispose of environmentally.

Store oil contaminated materials in a separate, specially marked container and dispose of environmentally.

#### 3.9.4 Cleaning work

Do not perform cleaning work while the motor is running.

Allow the engine to cool down before starting cleaning work.

Do not use gasoline or other easily inflammable substances for cleaning.

#### 3.9.5 After maintenance work

Reassemble all guards and protections.

### 3.10 Repair

Identify a defect machine with a warning sign.

Only operate the machine after it has been repaired.

When replacing safety relevant components, only original spare parts must be used.

Repairs must only be performed by an expert/qualified person.

### 3.11 Signage

Keep stickers and signage in good and legible condition and comply with their meaning.

Replace damaged and illegible stickers or signage immediately.

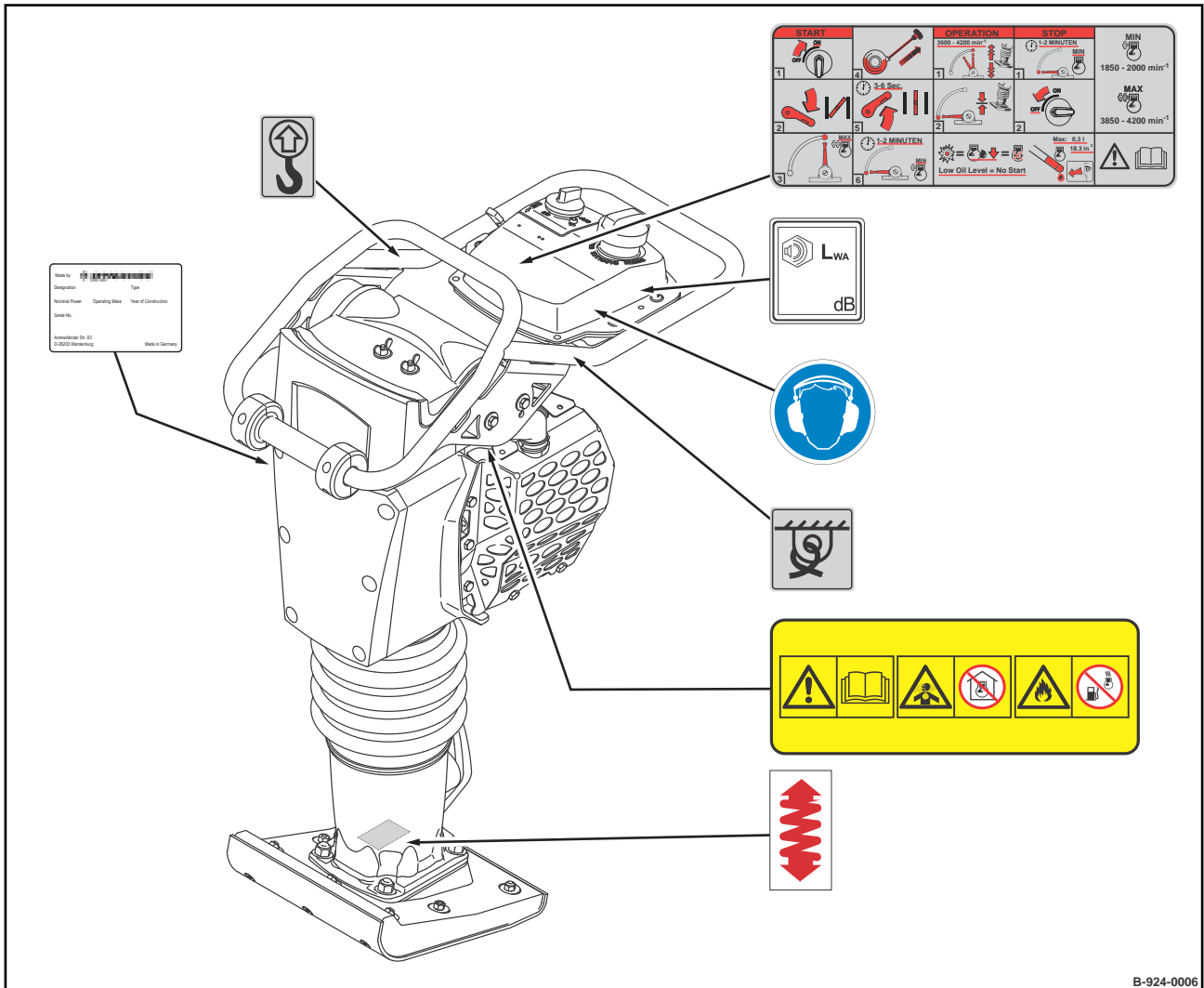

Fig. 6

## Concerning your safety – Signage



Warning sticker - Follow operating instructions

Fig. 7



Warning sticker - Do not inhale exhaust gases  
Do not operate inside closed areas.

Fig. 8



Warning sign - Fire hazard  
Fill up with fuel only when engine is stopped and has cooled down.

Fig. 9



Instruction sticker - Wear ear defenders

Fig. 10

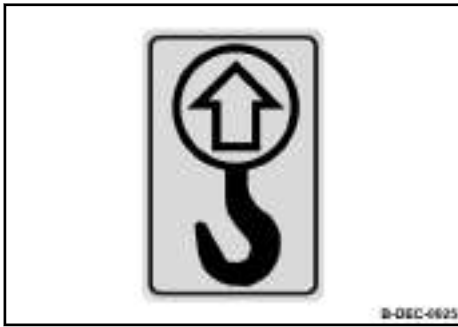

Information sticker - Lifting point

Fig. 11

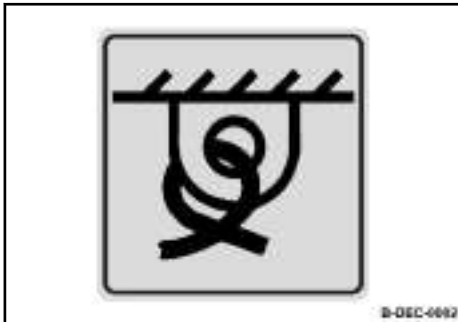

Information sticker - Lashing point

Fig. 12

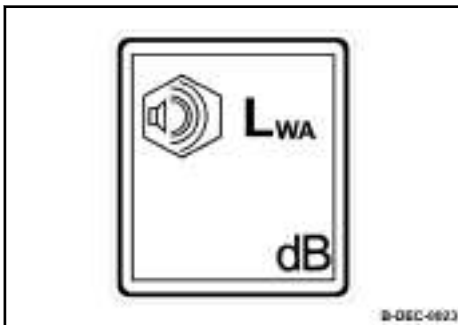

Information sticker - Guaranteed sound capacity level

Fig. 13

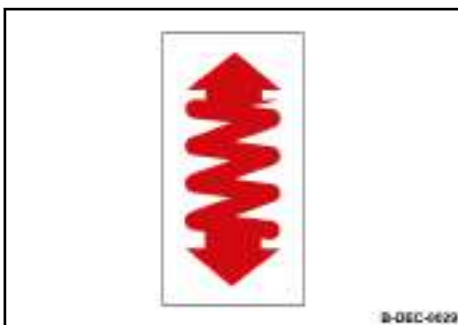

Information sticker - pre-tensioned spring

Fig. 14

## Concerning your safety – Signage



Fig. 15

Brief operating instructions

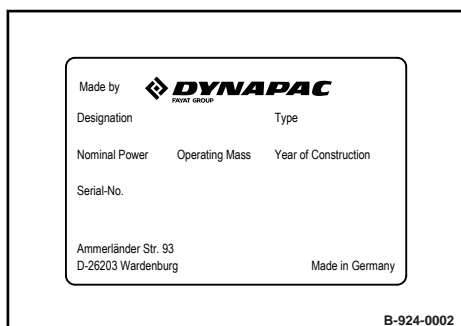
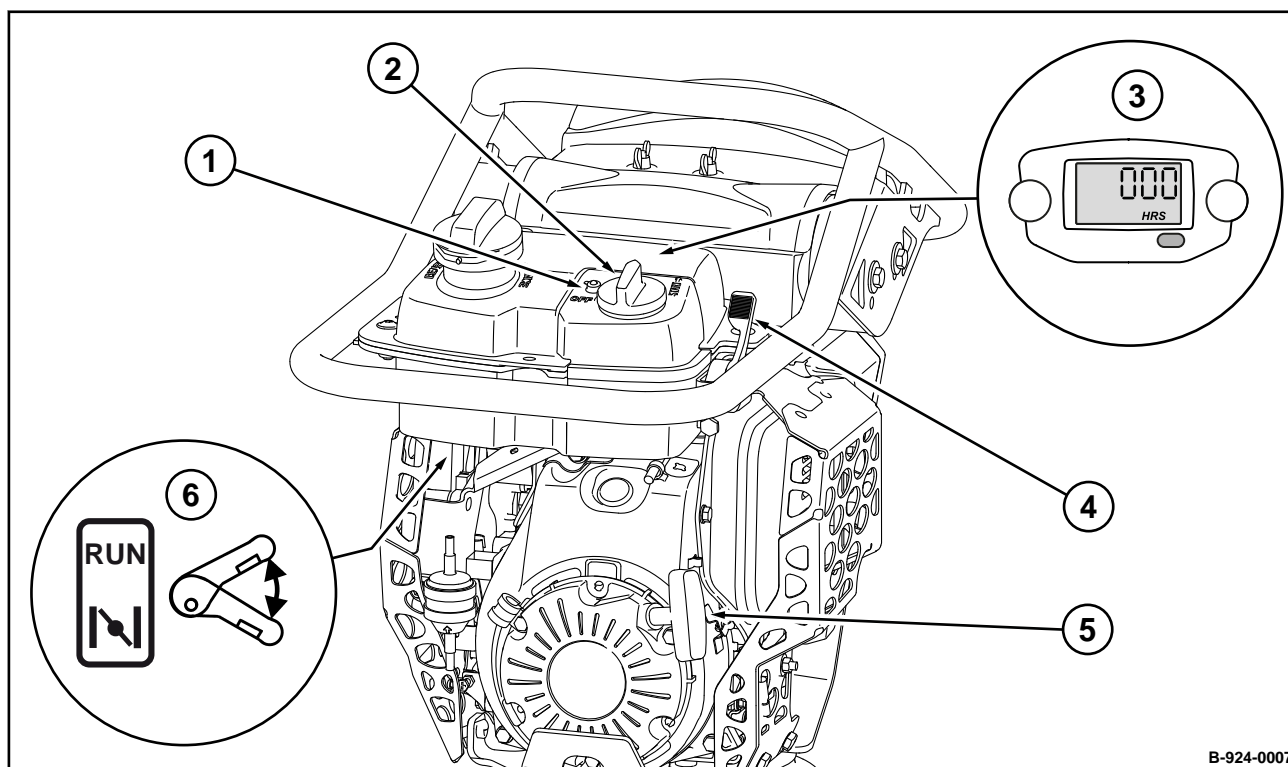

Fig. 16

Machine type plate (example)



## Indicators and control elements



B-924-0007

Fig. 17

- 1 Engine oil level warning light
- 2 Engine stop switch
- 3 Operating hour meter/engine rpm-meter
- 4 Throttle lever
- 5 Recoil starter
- 6 Choke lever



### 5.1 Notes on safety

If the following tests reveal damages or other defects, the machine must not be operated, until these deficiencies have been corrected.

Do not operate the machine with defective indicators and control elements.

Safety installations must not be removed or made ineffective.

Do not change any fixed settings.



#### **WARNING!**

##### **Health hazard caused by fuels and lubricants!**

- Safety regulations and environmental protection regulations must be followed when handling fuels and lubricants ↪ *Chapter 3.4 „Handling fuels and lubricants“ on page 23.*



#### **WARNING!**

##### **Danger of injury caused by rotating parts!**

- Before starting work on the machine make sure that the engine can not be started.

1. Park the machine safely ↪ *Chapter 6.4 „Parking the machine in secured condition“ on page 53.*

### 5.2 Visual inspections and function tests

1. Check fuel tank and lines for condition and leaks.
2. Check bolted connections for tight fit.
3. Check machine for contamination and damage.
4. Check the hydraulic oil cooler for dirt.
5. Check starter rope for chafing.

### 5.3 Checking the engine oil level



#### NOTICE!

#### Danger of engine damage!

- Use only oil of the permitted specification  
↳ Chapter 8.2.1 „Engine oil“ on page 63.



*The engine cannot be started if the engine oil level is too low.*

Protective equipment: ■ Working clothes  
■ Protective gloves

1. Park the machine so that the tamper foot is in horizontal position.
2. Clean the area around the oil dipstick (1).
3. Unscrew the dipstick and wipe it clean with a lint-free, clean cloth.
4. Insert the dipstick into the oil filler socket, do not screw it in, but pull it out again to check the oil level.
- 5.

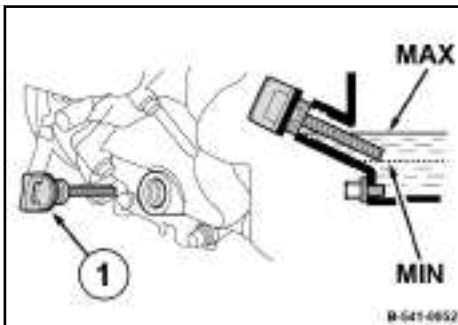

Fig. 18



#### NOTICE!

#### Danger of engine damage!

- Do not overfill the engine.

The oil level must always be between the "MIN"- and "MAX"-marks. If the oil level is too low, top up oil to the "MAX" mark immediately.

### 5.4 Checking the fuel level; topping up fuel



#### **DANGER!**

**Danger to life caused by explosive gas-air mixes!**

- Do not allow gasoline to come into contact with hot components.
- Smoking and open fire is prohibited.
- Keep away from heat sources, sparks and other sources of ignition.
- Do not spill any gasoline.



#### **NOTICE!**

**Danger of engine damage!**

- Monitor the entire refuelling process.
- Contaminated fuel can cause malfunction or even damage of the engine. If necessary, fill in fuel through a screen filter.
- Use only fuel of the permitted specification  
↳ *Chapter 8.2.2 „Fuel“ on page 63.*

Protective equipment: ■ Working clothes  
■ Safety shoes  
■ Protective gloves

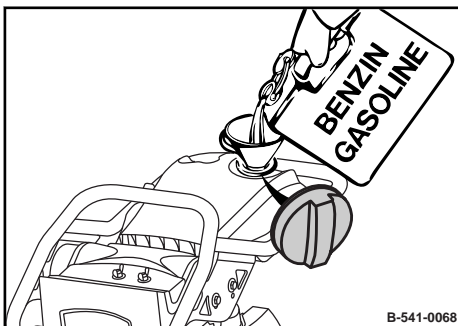

Fig. 19

1. Clean the area around the filling port.
2. Remove the cap and check the filling level visually.
3. Fill in fuel through a funnel with screen filter.
4. Close the cap.

### 5.5 Checking the rubber buffers

Protective equipment: ■ Working clothes  
■ Safety shoes  
■ Protective gloves

1. Park the machine safely ↪ *Chapter 6.4 „Parking the machine in secured condition“ on page 53.*
2. Allow the engine to cool down.
3. Check all rubber buffers for tight fit, cracks and tear-offs.
4. Replace damaged rubber buffers immediately.

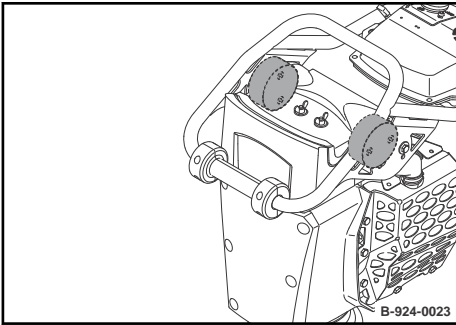

Fig. 20



### 6.1 Adjusting the guide handle

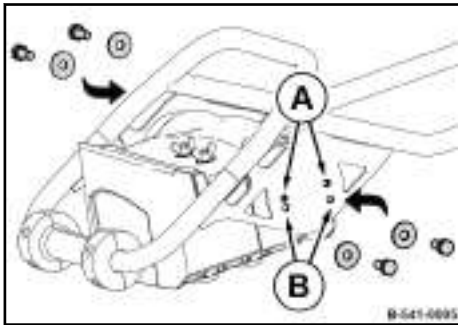

Fig. 21

Adjust the guide handle to the size of the operator using bores (A) and (B):

(A) - Lower guide handle position

(B) - Upper guide handle position

1. Park the machine in secured condition ↗ *Chapter 6.4 „Parking the machine in secured condition“ on page 53.*
2. Disassemble the fastening screws and washers on both sides.
3. Set the steering bow to the desired height.
4. Assemble the fastening screws and washers on both sides.

### 6.2 Starting the engine

Exhaust fumes contain toxic substances and can damage your health, cause unconsciousness or even death.



#### WARNING!

##### Danger of poisoning by exhaust gases!

- Do not inhale exhaust gases.
- Avoid operation in closed or partly closed rooms, or ensure adequate ventilation when working in trenches.



#### WARNING!

##### Loss of hearing caused by too high noise burdens!

- Wear your personal protective equipment (ear protection).

Protective equipment: ■ Hearing protection  
■ Safety shoes

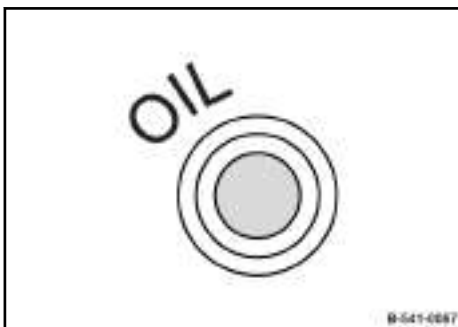

Fig. 22



*The engine does not start if the oil level is too low.*

*The engine oil level warning lamp flashes when operating the recoil starter.*

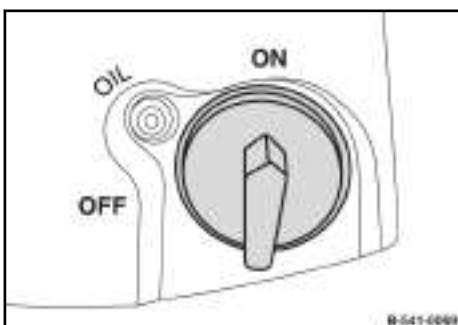

Fig. 23

1. Set the engine stop switch to position "ON".

## Operation – Starting the engine

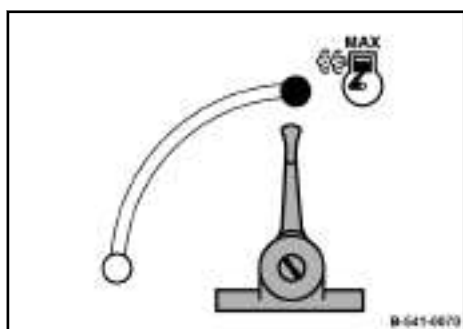

Fig. 24

2. Set the throttle lever to position "MAX".

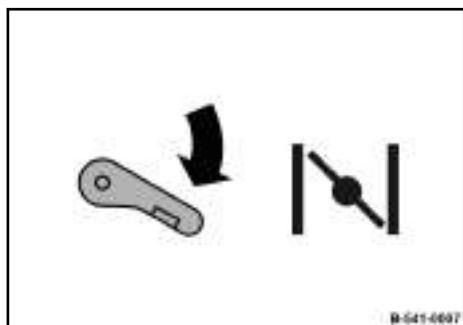

Fig. 25

3. Close the choke.



*Always close the choke to start a cold and warm engine.*

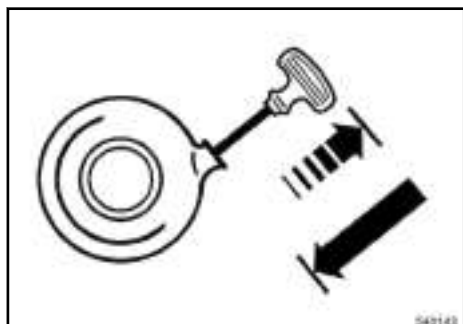

Fig. 26

4. Pull the rope by the starter handle, until resistance can be felt.
5. Guide the starter handle back to initial position.

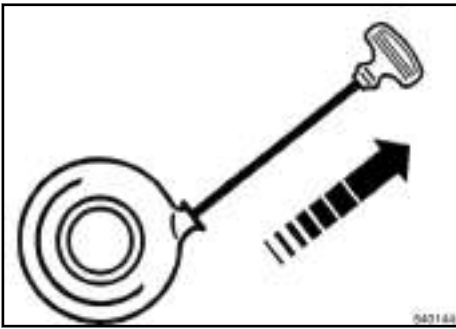

Fig. 27

6.



**CAUTION!**

**Danger of injury caused by uncontrolled machine movement!**

- Keep your feet clear of the tamper foot plate.
- Always hold on to a running machine.
- Always keep an eye on a running machine.



**NOTICE!**

**The starter rope may tear off!**

- Do not pull the starter rope all the way against the end stop.

Pull the starter handle quickly and with power.

7. Manually guide the starter handle back to initial position.
8. If the engine does not start during the first attempt, repeat the starting process.
9. Open the choke 3 to 6 seconds after the engine has started running.

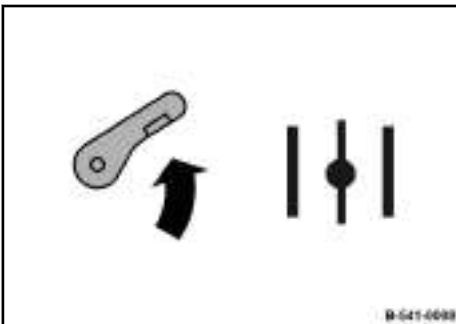

Fig. 28

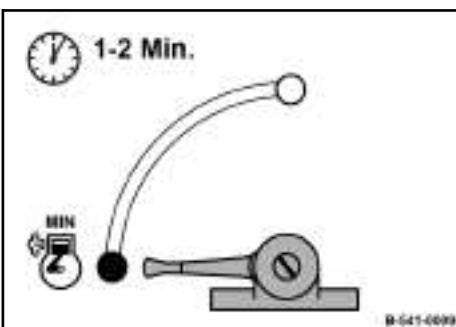

Fig. 29

10. Set the throttle lever to position "MIN" and let the engine run at idle speed to warm up for 1 to 2 minutes.



**NOTICE!**

**Danger of engine damage!**

- Warm up engine for a short while before starting work. Do not operate the engine immediately under full load.

11. Should the engine stop again after approx. 3 to 5 seconds:
  - Close the choke again.
  - Repeat the starting procedure.



*If the recoil starter is frequently operated with the choke closed, the engine will draw in too much fuel and is unable to start ( ↪ Chapter 10.3 „What to do if the engine has flooded“ on page 103).*

## 6.3 Operation

Guide the machine only by the guide handle.

Guide the machine so that your hands do not hit against solid objects.

For longer work breaks you should always park the machine in secured condition ↪ Chapter 6.4 „Parking the machine in secured condition“ on page 53.



### CAUTION!

**Danger of injury caused by uncontrolled machine movement!**

- Keep your feet clear of the tamper foot plate.
- Always hold on to a running machine.
- Always keep an eye on a running machine.



### WARNING!

**Loss of hearing caused by too high noise burdens!**

- Wear your personal protective equipment (ear protection).



*The layer thickness of the material to be compacted should not be higher than is possible for the machine to cope with.*

- Protective equipment:
- Working clothes
  - Safety shoes
  - Protective gloves
  - Hearing protection

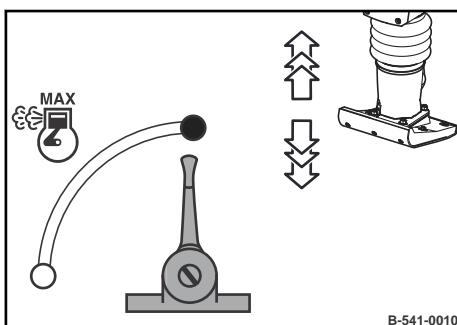

Fig. 30

1. Set the throttle lever to “MAX” position.
  - ⇒ The machine works with highest frequency.

## Operation – Operation

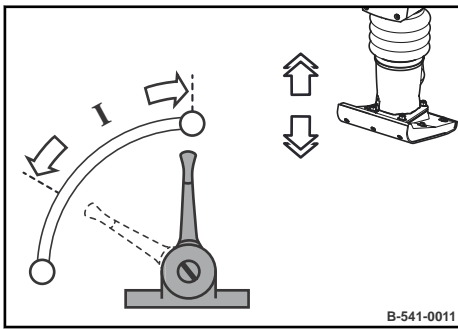

Fig. 31

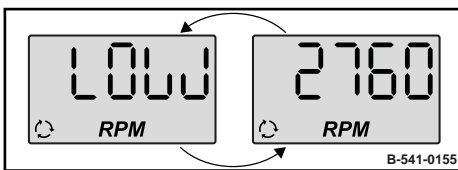

Fig. 32

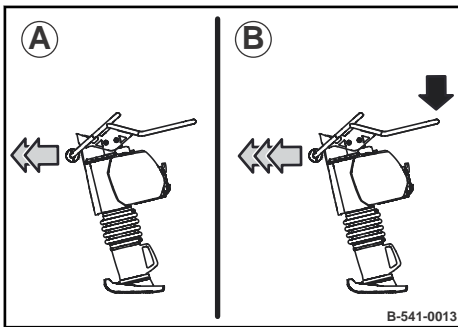

Fig. 33

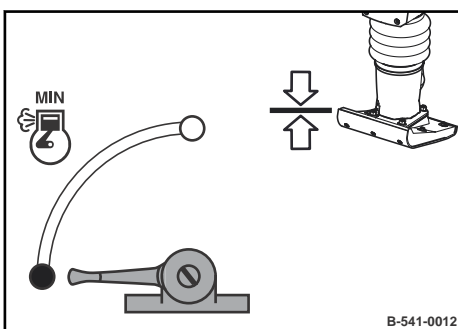

Fig. 34

2. To achieve uniform running you should actuate the throttle lever within the working range (I), depending on condition and density of the soil.  
⇒ Working range (I) = 3600 to 4200 min<sup>-1</sup>
3. If the machine jumps out of rhythm on heavily compacted soil, you may need to slightly change the engine speed and/or inclination of the machine.



### NOTICE!

#### The centrifugal clutch may be damaged!

- Do not work with engine speeds which are below the working range.

4. If the display [LOW] appears, increase the engine speed.

5. Adapt the marching speed by applying load to the guide handle:

(A) No load - slowly forward

(B) Heavy load - fast forward

6. Always shift the throttle lever to position "MIN" for short work breaks.

### 6.4 Parking the machine in secured condition

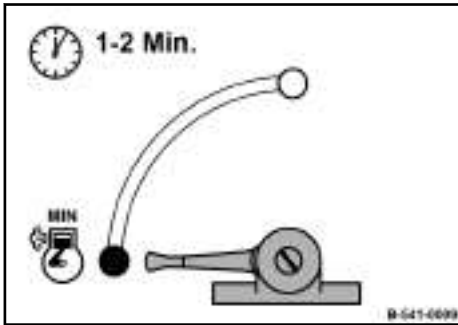

Fig. 35

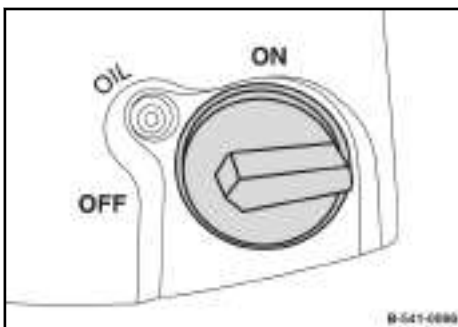

Fig. 36

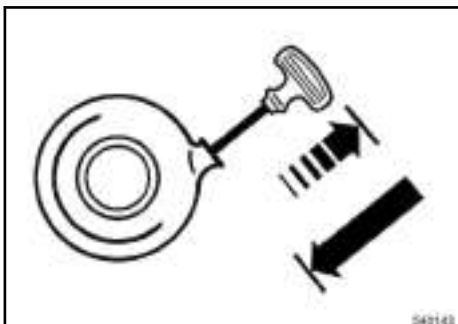

Fig. 37

1. Set the throttle lever to position "MIN" (idle speed).



#### **NOTICE!**

#### **Danger of engine damage!**

- Do not shut down the engine all of a sudden from full load speed, but let it idle for about two minutes.

2. Set the engine stop switch to position "OFF".

⇒ The engine is shut down.

3. Park the machine so that it cannot turn over.

4. Pull the rope by the starter handle, until resistance can be felt. Guide the starter handle back to initial position.

⇒ This procedure protects against moisture deposits inside the engine.

## Operation – Operating hour meter/engine rpm-meter

### 6.5 Operating hour meter/engine rpm-meter



Engine off	Operating the function key (1) switches between operating hours, hour counter and service indicator
Engine on	Engine speed  If the remaining period until the next maintenance is under two hours, the maintenance indicator appears for approx. 30 seconds after starting the engine.

Fig. 38

Display	Description
	Engine speed in the working range
	Engine speed below the working range. Display [LOW] alternately displayed with the engine speed. to increase the engine speed.
	Operating hours
	Hour meter
	Maintenance display [in ...] together with the remaining period (in hours) until the next maintenance. Set maintenance intervals: <ul style="list-style-type: none"> <li>■ after the first 25 operating hours</li> <li>■ then every 100 operating hours</li> </ul>

### Resetting the maintenance indicator / hour meter

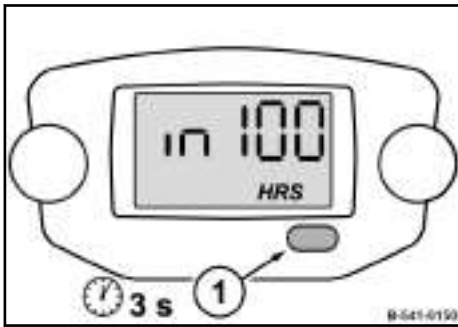

Fig. 39

1. Shut down the engine.
2. Keep pressing the function key (1), until the maintenance indicator or the hour meter is displayed.
3. Press the function key for three seconds.
  - ⇒ The maintenance indicator is reset to 100 hours.
  - The hour meter is reset to zero hours.





### 7.1 Loading the machine

Loads may only be attached and hoisted by an expert/qualified person.

Do not use lifting points that are damaged or impaired in any other way.

Only use lifting and lashing tackle with sufficient load bearing capacity for the weight to be loaded. Minimum load bearing capacity of lifting tackle: see operating weight ↪ *Chapter 2 „Technical data“ on page 11.*

Always use appropriate lifting and lashing tackle at the lifting and lifting points.

Use lifting tackle only in the specified loading direction.

Lifting tackle must not be damaged by machine parts.

When lifting the machine, make sure the load does not move in an uncontrolled way. If necessary, hold the load steady with guide ropes.

Protective equipment: ■ Protective gloves  
■ Safety shoes

1. Park the machine safely ↪ *Chapter 6.4 „Parking the machine in secured condition“ on page 53.*
2. Make sure that no fuel will be spilled from the tank during transport:
  - Close the fuel tank tightly.
  - Consider the filling quantity in the tank in case of temperature fluctuations (pressure relief valve in tank lid); drain off fuel if necessary.
3. Attach the lifting tackle to the dedicated lifting eye.
- 4.

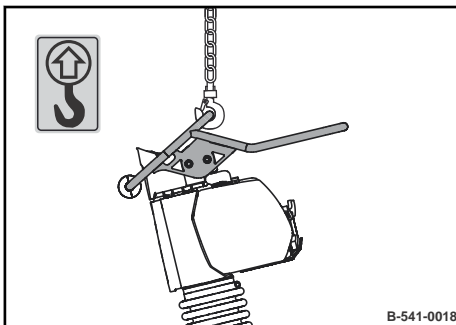

Fig. 40



#### **DANGER!**

**Danger to life caused by suspended loads!**

- Do not step or stand under suspended loads.

Lift the machine carefully and set down again at the intended location.

## Loading/transporting the machine – Loading the machine

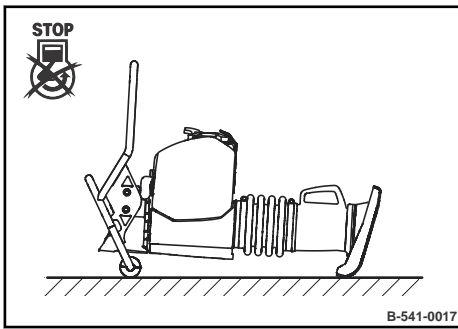

Fig. 41

5.



### **WARNING!**

#### **Danger of burning on hot components!**

- Wear your personal protective equipment (protective gloves, protective clothing).
- Avoid touching hot components.

Lay the machine on the rollers.

### 7.2 Lashing the machine to the transport vehicle

Do not use lashing points that are damaged or impaired in any way.

Always use appropriate lashing tackle at the lashing points.

Use lashing tackle only in the specified loading direction.

Lashing tackle must not be damaged by machine parts.

Protective equipment: ■ Working clothes  
■ Protective gloves  
■ Safety shoes



#### **WARNING!**

#### **Danger of burning on hot components!**

- Wear your personal protective equipment (protective gloves, protective clothing).
- Avoid touching hot components.

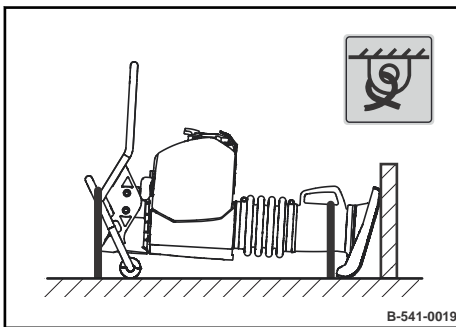

Fig. 42

1. Lean the tamper foot against the side wall of the transport vehicle.
2. Fasten the machine on the transport vehicle with at least two suitable lashing belts.



### 8.1 Preliminary remarks and safety notes



#### **DANGER!**

#### **Danger to life caused by an operationally unsafe machine!**

- The machine must only be serviced by qualified and authorized personnel.
- Follow the safety regulations for maintenance work ↪ *Chapter 3.9 „Maintenance work“ on page 31.*



#### **WARNING!**

#### **Health hazard caused by fuels and lubricants!**

- Safety regulations and environmental protection regulations must be followed when handling fuels and lubricants ↪ *Chapter 3.4 „Handling fuels and lubricants“ on page 23.*

Wear your personal protective equipment.

Do not touch hot components.

Park the machine on horizontal, level, firm ground.

Secure the machine against accidental tipping over.

Perform maintenance work only with the engine shut down and the spark plug connector disconnected.

Make sure that the engine cannot be accidentally started during maintenance work.

Thoroughly clean machine and engine before starting maintenance work.

Do not leave any tools or other objects, that could cause damage, in or on the machine.

After maintenance work has been completed, dispose of fuels and lubricants, filters, sealing elements and cleaning cloths in an environmentally friendly way.

After all maintenance work is completed reinstall all guards and safety installations.

### 8.2 Fuels and lubricants

#### 8.2.1 Engine oil

##### 8.2.1.1 Oil quality

The following engine oil specifications are permitted:

- Engine oils for four-stroke engines acc. to API-classification SJ or higher

Avoid mixing of engine oils.

##### 8.2.1.2 Oil viscosity

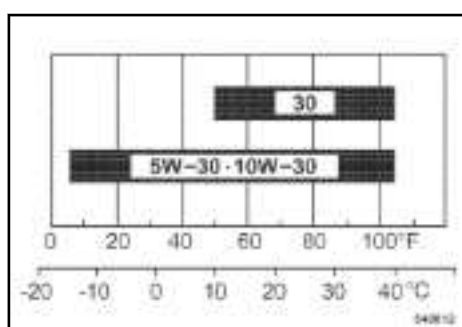

Fig. 43

Since engine oil changes its viscosity with the temperature, the ambient temperature at the operating location of the engine is of utmost importance when choosing the viscosity class (SAE-class).

The temperature data of the SAE-class always refers to fresh oils. In travel operation engine oil ages because of soot and fuel residues. This adversely affects the properties of the engine oil, especially under low ambient temperatures.

SAE 10W-30 is recommended for general use.

You may alternatively use 15W-40 (except under low temperatures).

##### 8.2.1.3 Oil change intervals

Oil change interval: semi-annually or every 100 operating hours.

### 8.2.2 Fuel

#### 8.2.2.1 Fuel quality

Use unleaded gasoline with a research octane number of 91 or higher (or octane number 86 or higher).

Use unleaded standard grade gasoline with maximum 10 percent by volume of ethanol (E10) or maximum 5 percent by volume of methanol.

Methanol must also contain co-solvents and corrosion inhibitors.

Do not use any fuel with a higher ethanol or methanol content.

The use of fuels with a higher ethanol or methanol content will cause starting and/or power problems or even cause damage in the fuel system.

### 8.2.2.2 Fuel stabilizer

If the machine is only occasionally used (if it is out of use for longer than four weeks), mix in the correct amount of fuel stabilizer directly after you have purchased fresh fuel.

The fuel stabilizer has a limited shelf life.

Please follow the instructions of the manufacturer concerning the correct mixing ratio and shelf life.

Mixing in fuel stabilizer does not regenerate old fuel.

### 8.2.3 Gear oil SAE 75W-90

Use a fully synthetic gear oil in accordance with SAE 75W-90, API GL5 with a kinematic viscosity of at least 16 mm<sup>2</sup>/s at 100 °C (212 °F).

### 8.3 List of fuels and lubricants

Assembly group	Fuel or lubricant		Spare parts number	Filling quantity
	Summer	Winter		Observe the level mark!
Engine oil	SAE 10W-30 Specification: ↪ Chapter 8.2.1 „Engine oil“ on page 63			0.3 l (0.08 gal us)
	SAE 30			
Fuel	Gasoline (unleaded) Specification: ↪ Chapter 8.2.2 „Fuel“ on page 63			3 l (0.8 gal us)
	Fuel stabilizer Specification: ↪ Chapter 8.2.2.2 „Fuel stabilizer“ on page 64			
Rammer foot	SAE 75W-90, API GL-5 Specification: ↪ Chapter 8.2.3 „Gear oil SAE 75W-90“ on page 64			0.75 l (0.20 gal us)

### 8.4 Running-in instructions

#### 8.4.1 General

The following maintenance work must be performed when running in new machines or overhauled engines.



#### **NOTICE!**

##### **Danger of engine damage!**

- Up to approx. 250 operating hours check the engine oil level twice every day.

Depending on the load the engine is subjected to, the oil consumption will drop to the normal level after approx. 100 to 250 operating hours.

#### 8.4.2 After 25 operating hours

1. Change the engine oil ↪ *Chapter 8.8.1 „Changing the engine oil“ on page 73.*
2. Check the idle speed and the max. speed of the engine, adjust if necessary ↪ *Chapter 8.9.6 „Checking, adjusting the engine speed“ on page 87.*
3. Check engine and machine for leaks.
4. Retighten the fastening screws on air filter, exhaust and other attachments.
5. Retighten the bolted connections on the machine.

## 8.5 Maintenance Table

No.	Maintenance works	Page
<b>Weekly</b>		
8.6.1	<i>Checking, cleaning the air filter</i>	68
<b>Monthly</b>		
8.7.1	<i>Checking the tamper foot</i>	71
<b>Semi-annually</b>		
8.8.1	<i>Changing the engine oil</i>	73
<b>Annually</b>		
8.9.1	<i>Checking, adjusting the valve clearance</i>	74
8.9.2	<i>Replacing the spark plug</i>	79
8.9.3	<i>Replacing the fuel filter</i>	80
8.9.4	<i>Cleaning the fuel screen</i>	83
8.9.5	<i>Replacing the air filter</i>	85
8.9.6	<i>Checking, adjusting the engine speed</i>	87
8.9.7	<i>Replacing the starter rope</i>	90
8.9.8	<i>Changing the oil in the rammer foot</i>	92
<b>As required</b>		
8.10.1	<i>Cleaning the machine</i>	94
8.10.2	<i>Checking, cleaning the spark plug</i>	94

### 8.6 Weekly

#### 8.6.1 Checking, cleaning the air filter



#### NOTICE!

##### Danger of engine damage!

- Never start the engine after removing the air filter.
- Do not let dirt drop into the air duct.
- Do not continue using a damaged or soiled air filter. If in doubt use a new air filter.

Protective equipment: ■ Working clothes  
■ Safety shoes  
■ Protective gloves  
■ Safety goggles

1. Park the machine safely ↪ *Chapter 6.4 „Parking the machine in secured condition“ on page 53.*
2. Allow the engine to cool down.

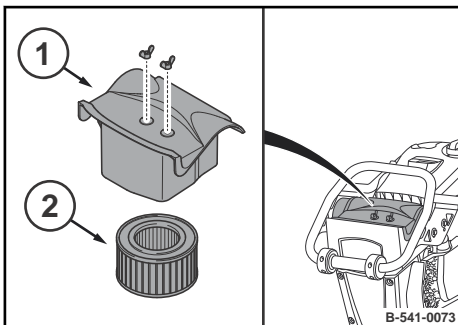

Fig. 44

Fig. 45

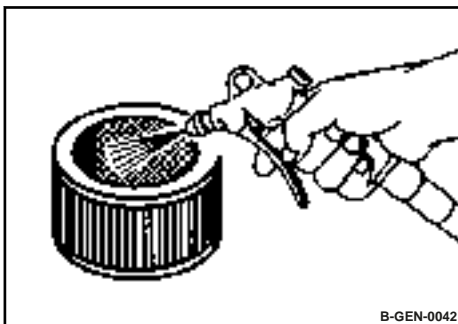

Fig. 46

3. Disassemble the cover (1) and air filter (2).
4. Clean the cover.
- 5.



#### CAUTION!

##### Danger of eye injuries caused by particles flying around!

- Wear your personal protective equipment (safety gloves, protective working clothes, goggles).

Blow the air filter out with dry compressed air (max. 6 bar (87 psi)) from inside to outside by moving the gun up and down inside the element, until it is free of dust.

6. Check seals and air filter for damage.
7. Replace the air filter if it is damaged.
8. Insert the air filter and reassemble the cover.

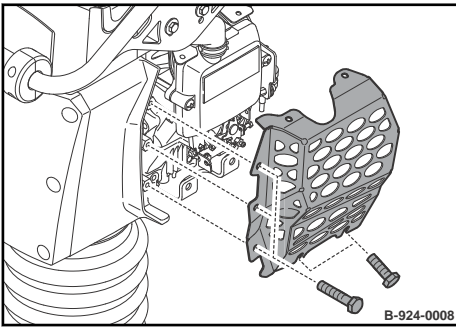

Fig. 47

9. Disassemble the left engine guard.

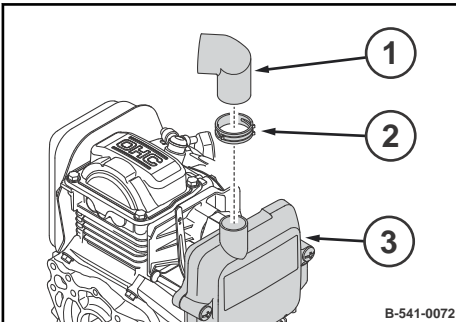

Fig. 48

10. Pull the air feed hose (1) and the hose clamp (2) off the cover (3).

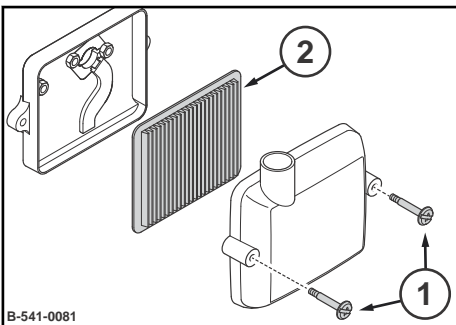

Fig. 49

11. Unscrew the fastening screws (1).  
 12. Disassemble the cover and air filter (2).  
 13. Wipe the inside of the air filter housing with a clean cloth.

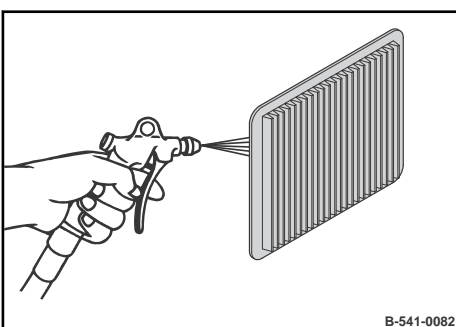

Fig. 50

- 14.



**CAUTION!**

**Danger of eye injuries caused by particles flying around!**

- Wear your personal protective equipment (safety gloves, protective working clothes, goggles).

Blow the air filter out from inside to outside with dry compressed air (max. 2 bar (29 psi)), until all dust has been removed.

15. Check seals and air filter for damage.  
 16. Replace the air filter if it is damaged.

## Maintenance – Weekly

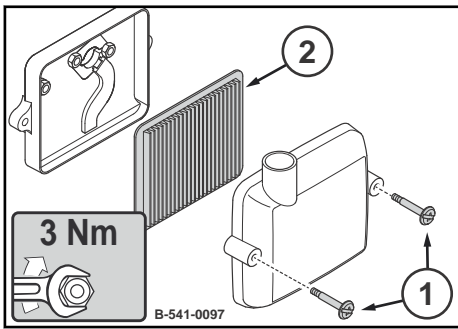

Fig. 51

17. Slide the air filter (2) carefully into the housing.
18. Assemble the cover (3) with fastening screws (1), tightening torque: 3 Nm (2 ft·lbf).

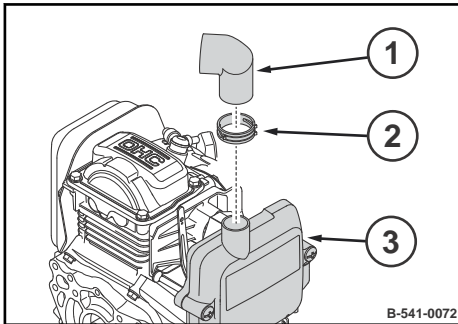

Fig. 52

19. Connect the air hose (1) with the hose clamp (2) to the cover (3).

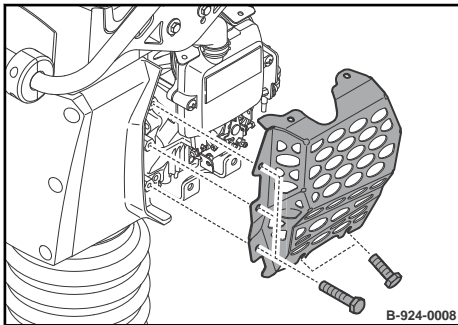

Fig. 53

20. Assemble the left engine guard.

## 8.7 Monthly

### 8.7.1 Checking the tamper foot



#### NOTICE!

#### Components may get damaged!

- Use only oil of the permitted specification  
 ↪ Chapter 8.3 „List of fuels and lubricants“ on page 65.

Protective equipment: ■ Working clothes  
 ■ Protective gloves

1. Park the machine in secured condition ↪ Chapter 6.4 „Parking the machine in secured condition“ on page 53.
2. Park the machine so that the tamper foot is in horizontal position.
3. Allow the machine to cool down.
4. Clean the sight glass.
5. Check the oil level.
6. The oil must be visible between the middle and the upper edge of the oil level inspection glass, if necessary top up oil up to the bottom edge of the filling opening.

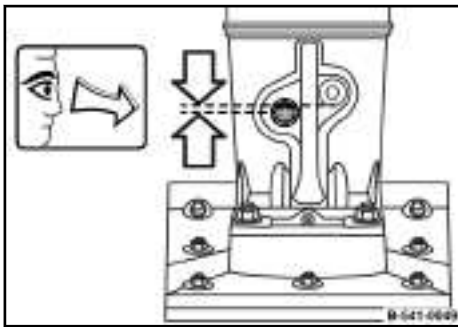

Fig. 54



*The upper edge of the inspection glass equals the bottom edge of the oil filling bore.*

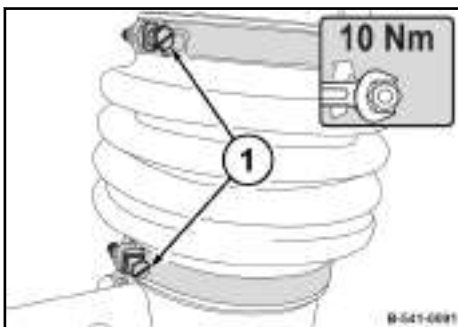

Fig. 55

7. Check concertina wall for condition, damage and tight fit.
8. Check the hose clamps for tight fit, tightening torque for screws (1): 10 Nm (7.4 ft-lbf).

## Maintenance – Monthly

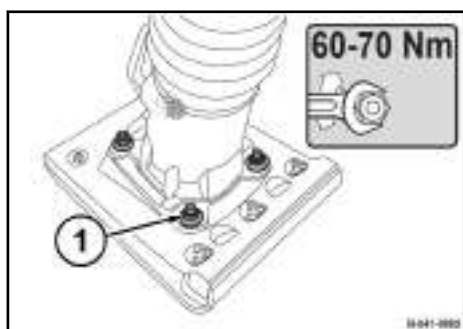

Fig. 56

9. Retighten 4 screws (1) on the tamper foot plate, tightening torque: 60 - 70 Nm (44 - 52 ft·lbf).

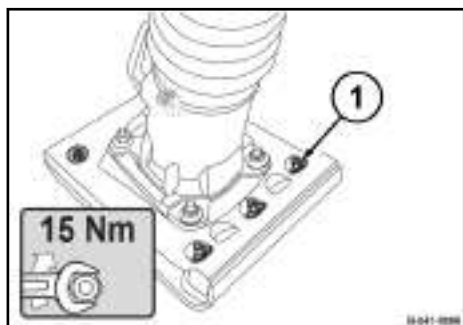

Fig. 57

10. Retighten 5 screws (1) on the tamper foot plate, tightening torque: 15 Nm (11 ft·lbf).

## 8.8 Semi-annually

### 8.8.1 Changing the engine oil



**NOTICE!**

**Danger of engine damage!**

- Change the oil only with the engine at operating temperature.
- Use only oil of the permitted specification  
 ↳ *Chapter 8.2.1 „Engine oil“ on page 63.*
- Filling quantity: ↳ *Chapter 8.3 „List of fuels and lubricants“ on page 65*

Protective equipment: ■ Working clothes  
 ■ Protective gloves

1. Park the machine in secured condition ↳ *Chapter 6.4 „Parking the machine in secured condition“ on page 53.*
2. Park the machine so that the tamper foot is in horizontal position.



Fig. 58



**WARNING!**

**Danger of burning on hot components!**

- Wear your personal protective equipment (protective gloves, protective clothing).
- Avoid touching hot components.

3.

Clean the area around oil dipstick (1) and drain plug (3).

4. Unscrew the oil dipstick.
5. Unscrew the drain plug and collect any oil running out.
6. Clean the oil drain plug and screw it back in with a new seal ring (2).
7. Fill in fresh oil up to the bottom edge of the filler bore.
8. Push the oil dipstick (1) back in.
9. Check for leaks after a short test run.
10. Check the oil level on the dipstick, correct if necessary.
11. Dispose of oil in an environmentally friendly way.

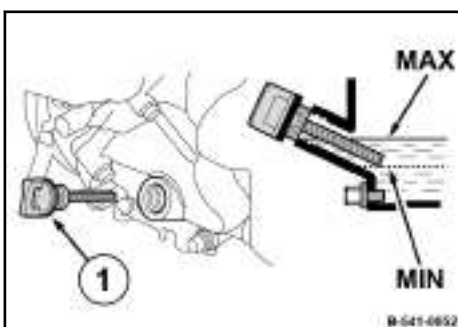

Fig. 59

### 8.9 Annually

#### 8.9.1 Checking, adjusting the valve clearance



#### NOTICE!

#### Danger of engine damage!

We recommend to have this work carried out by trained personnel or our after sales service.

- Before checking the valve clearance let the engine cool down.

#### Preparations

Protective equipment: ■ Working clothes  
■ Safety shoes  
■ Protective gloves

1. Park the machine safely ↪ *Chapter 6.4 „Parking the machine in secured condition“ on page 53.*
2. Let the engine cool down to ambient temperature.
3. Pull the air feed hose (1) and the hose clamp (2) off the cover (3).

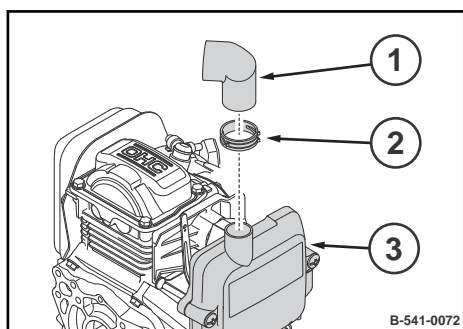

Fig. 60

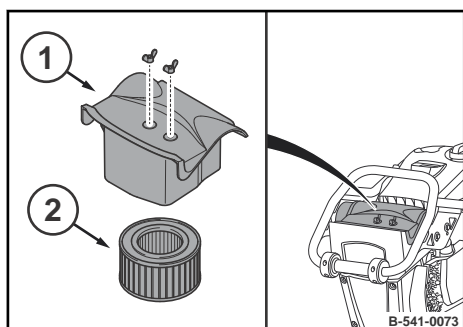

Fig. 61

4. Disassemble the cover (1) and air filter (2).

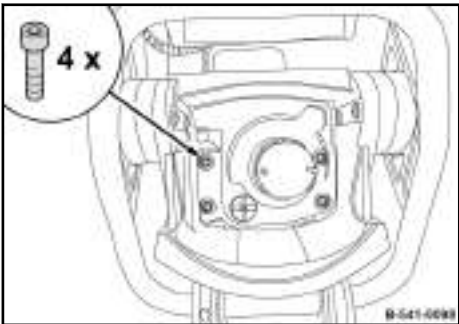

Fig. 62

5. Disassemble the guide handle fastening screws.

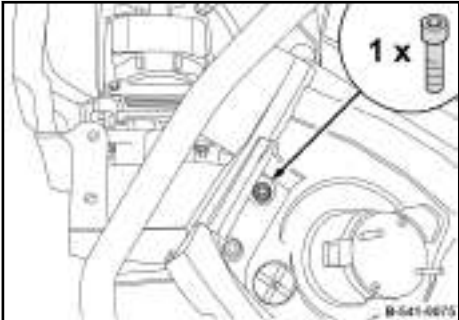

Fig. 63

6. **NOTICE!**  
**Components may get damaged!**  
– Do not tear off any hoses or cables.

Remove the guide handle and secure it to the housing with a fastening screw.

Tighten the fastening screw hand-tight.

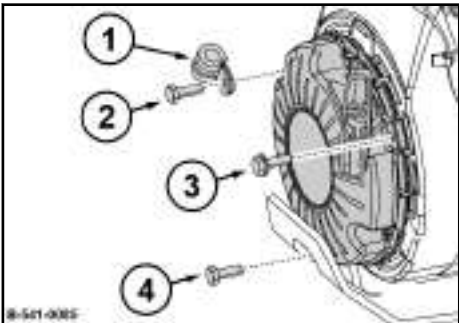

Fig. 64

7. Disassemble the recoil starter.

- 1 Pipe clamp
- 2 Screw M6x18
- 3 Screw M6x14
- 4 Screw M6x18

## Maintenance – Annually

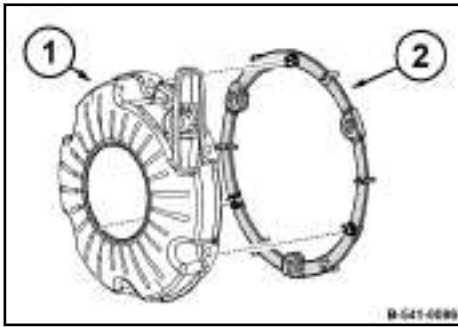

Fig. 65

### Checking, adjusting the valve clearance

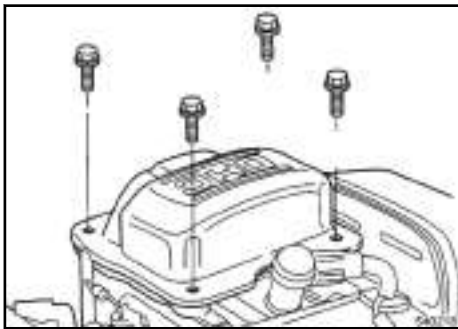

Fig. 66



Fig. 67

8. If necessary, remove the spacer ring (2) from the engine.

#### Valve clearance:

Intake valve (IN)	0.15 mm (0.006 in)
Exhaust valve (EX)	0.20 mm (0.008 in)

1. Unscrew the fastening screws for the cylinder head cover.

- 2.



#### NOTICE!

#### Components may get damaged!

- Do not apply force to remove the cylinder head cover.

Insert a screwdriver into the recess and lever the cylinder head cover carefully off.

3. Check the cylinder head cover for damage.
4. Replace a damaged or bent cylinder head cover.

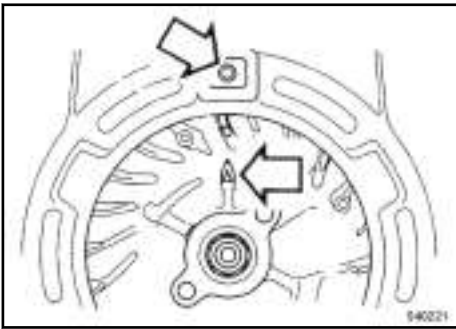

Fig. 68

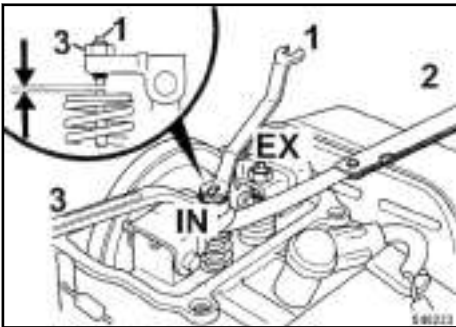

Fig. 69

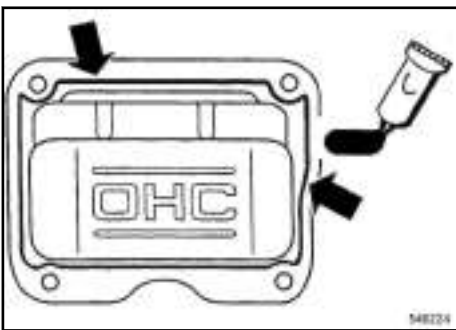

Fig. 70

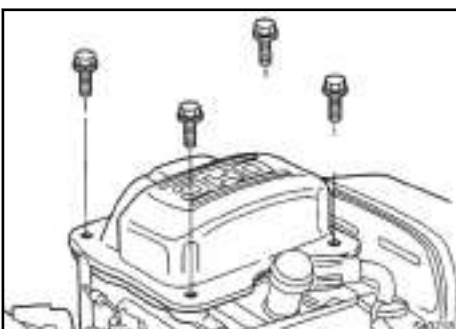

Fig. 71

5. Align the alignment mark on the flywheel rib with the top bore of the fan cover.
  - ⇒ The piston is in top dead centre position of the compression stroke.
6. However, if the exhaust valve is open when aligning the marks, the flywheel must be turned further by 360°.
7. Check the valve clearance with a feeler gauge (2).
8. To adjust the valve, hold the valve adjustment screw (1) and loosen the locking nut (3).
9. Turn the valve adjustment screw in or out, as required.
10. Retighten the locking nut, tightening torque: 8 Nm (6 ft·lbf).
11. Clean the sealing faces on cylinder head cover and cylinder block.
12. Apply a bead of liquid sealant, approx. 1.5 to 2.0 mm (0.06 to 0.08 in) in diameter, to the inner side of the cylinder head cover.
  - i** *Liquid sealant: Three Bond 1207B or similar.*
13. Attach the cylinder head cover to the cylinder block within the next 10 minutes.
14. Tighten the fastening screws.

## Maintenance – Annually

### Concluding work

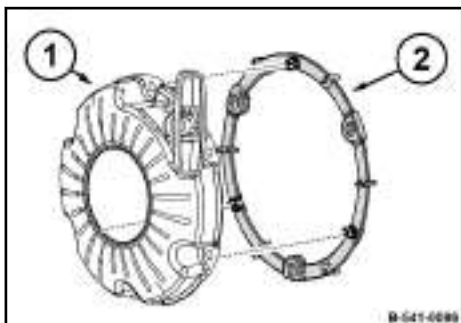

Fig. 72

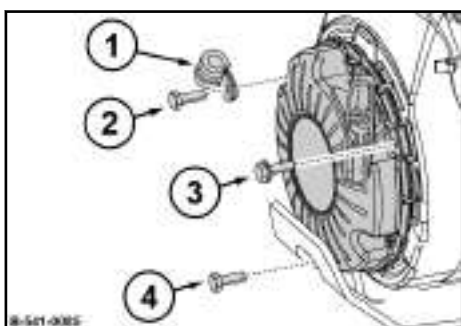

Fig. 73

- 1 Pipe clamp
- 2 Fastening screw M6x18
- 3 Fastening screw M6x14
- 4 Fastening screw M6x18

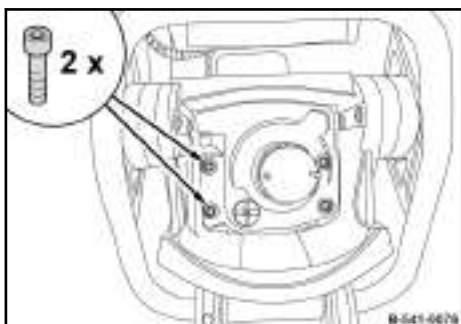

Fig. 74

1. Clip in the spacer ring (2) on the recoil starter (1).

2.



#### NOTICE!

**The recoil starter may get damaged!**

- Do not mix up the fastening screws for the recoil starter by mistake.

Assemble the recoil starter.

3. Attach the guide handle and tighten the right hand fastening screws hand-tight.

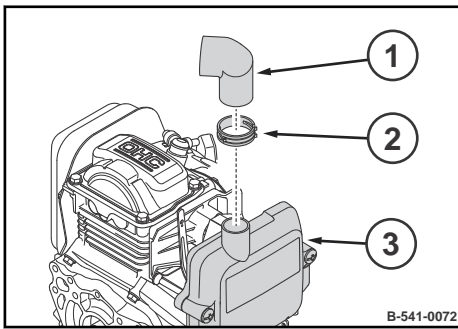

Fig. 75

4. Connect the air hose (1) with the hose clamp (2) to the cover (3).

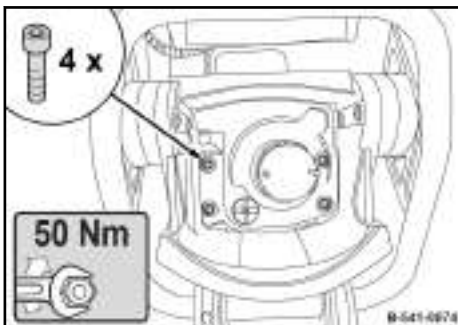

Fig. 76

5. Assemble the fastening screws, tightening torque: 50 Nm (37 ft·lbf).

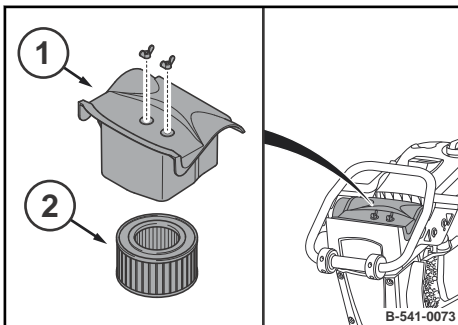

Fig. 77

6. Assemble air filter (2) and cover (1).
7. Wait another 20 minutes before starting the engine.
8. After a short test run, check the engine for leaks.

### 8.9.2 Replacing the spark plug



**NOTICE!**

**Danger of engine damage!**

- Do not use spark plugs with incorrect heat value.

**Recommended spark plugs:**

NGK	CR5HSB
DENSO	U16FSR-UB

Protective equipment: ■ Working clothes  
■ Protective gloves

Special tool: ■ 16 mm spark plug spanner

1. Park the machine in secured condition ↪ *Chapter 6.4 „Parking the machine in secured condition“ on page 53.*
2. Allow the engine to cool down for at least 15 minutes.
3. Pull off the spark plug connector (1).
4. Clean the area around the spark plug.
5. Unscrew the spark plug with a 16 mm spark plug spanner (2).
6. Check the electrode gap of the new spark plug with a feeler gauge, if necessary, adjust the gap.  
⇒ **Nominal value:** 0.6 - 0.7 mm (0.024 - 0.028 in)
7. Carefully screw in the spark plug by hand.
8. Once the sealing surface of the new spark plug is in contact, tighten for another 1/2 turn with the spark plug spanner.

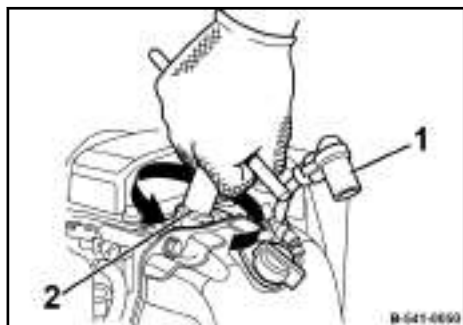

Fig. 78

### 8.9.3 Replacing the fuel filter



#### **DANGER!**

**Danger to life caused by explosive gas-air mixes!**

- Do not allow gasoline to come into contact with hot components.
- Smoking and open fire is prohibited.
- Keep away from heat sources, sparks and other sources of ignition.
- Do not spill any gasoline.

Protective equipment: ■ Working clothes  
■ Safety shoes  
■ Protective gloves

#### Preparations

1. Park the machine safely ↪ *Chapter 6.4 „Parking the machine in secured condition“ on page 53.*

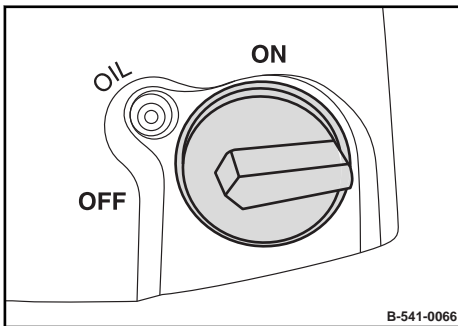

Fig. 79

3. Set the engine stop switch to position "OFF".  
⇒ The fuel valve is closed.

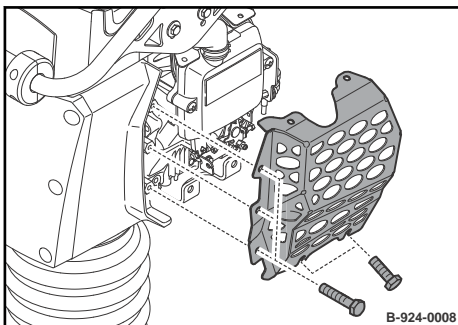

Fig. 80

4. Disassemble the left engine guard.

### Disassembling the fuel filter

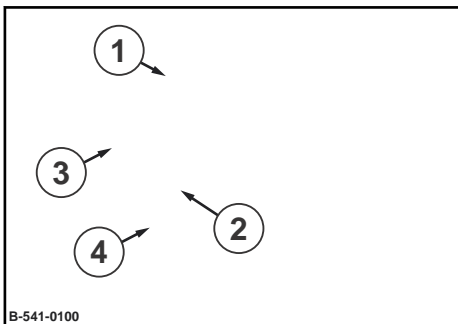

Fig. 81

5. Loosen the hose clamps (1) and (4) and pull the fuel hoses off the fuel filter (2).
6. Loosen fastening screw (3).
7. Take off the old fuel filter.

## Maintenance – Annually

### Assembling the fuel filter and filling it with fuel

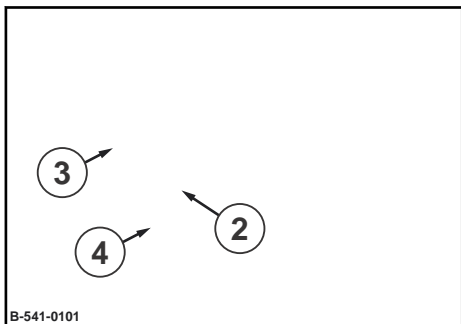

Fig. 82

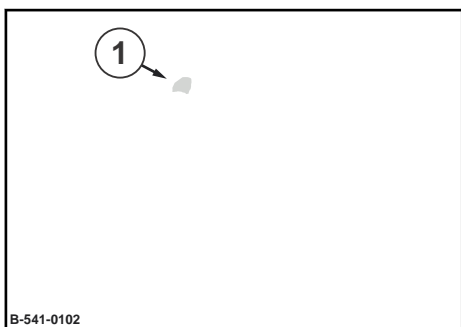

Fig. 83

### Concluding work

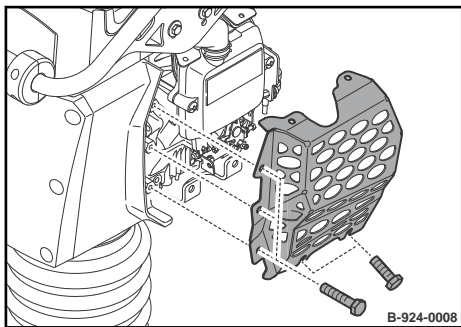

Fig. 84

8. Install the new fuel filter (2) by observing the flow direction.
9. Tighten the fastening screw (3), tightening torque: 10 Nm (7.4 ft·lbf).
10. Connect the lower fuel hoses to the fuel filter with hose clamp (4).
11. Open the fuel valve (engine stop switch in position "ON"), until the fuel filter is filled with fuel.
12. Close the fuel valve (engine stop switch in position "OFF").
13. Connect the upper fuel hose to the fuel filter with the hose clamp (1).
14. Assemble the left engine guard.
15. Dispose of fuel and fuel filters in line with environmental regulations.

### 8.9.4 Cleaning the fuel screen



**DANGER!**

**Danger to life caused by explosive gas-air mixes!**

- Do not allow gasoline to come into contact with hot components.
- Smoking and open fire is prohibited.
- Keep away from heat sources, sparks and other sources of ignition.
- Do not spill any gasoline.

Protective equipment: ■ Working clothes  
 ■ Protective gloves

1. Park the machine in secured condition ↪ *Chapter 6.4 „Parking the machine in secured condition“ on page 53.*
2. Loosen hose clamp (1) and pull the fuel hoses off the fuel valve (2).

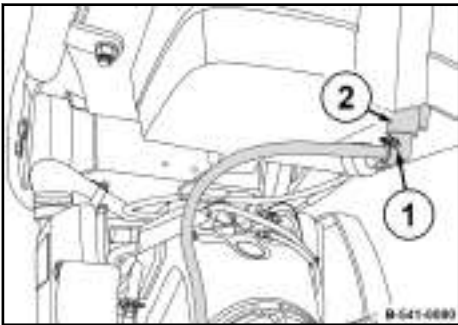

Fig. 85

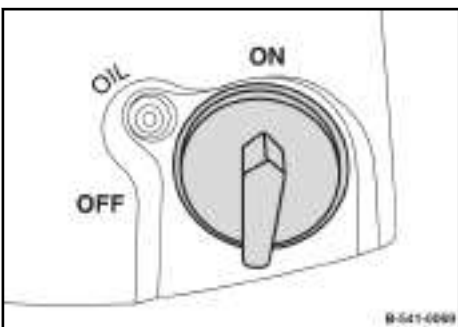

Fig. 86

3. Open the fuel valve (engine stop switch in position "ON") and catch running out fuel.

## Maintenance – Annually

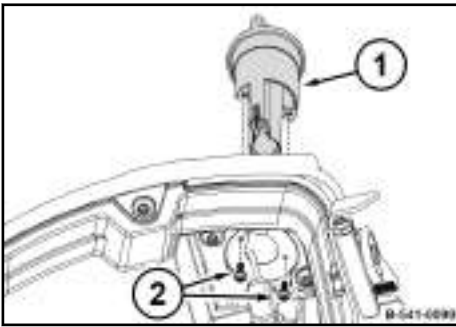

Fig. 87

4. Unscrew the screws (2) and remove the engine stop switch (1).

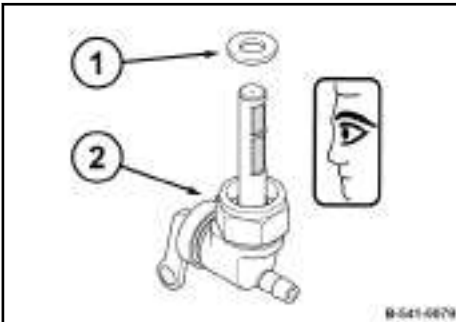

Fig. 88

5. Unscrew the fuel valve (2) and remove the seal (1).
6. Clean the screen and check for damage.
7. Replace the fuel valve if damaged.
8. Assemble the fuel valve with a new seal

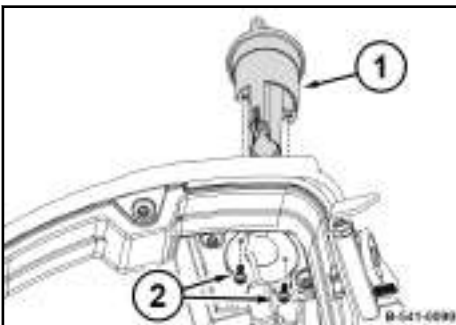

Fig. 89

9. Assemble the engine stop switch (1) with screws (2).

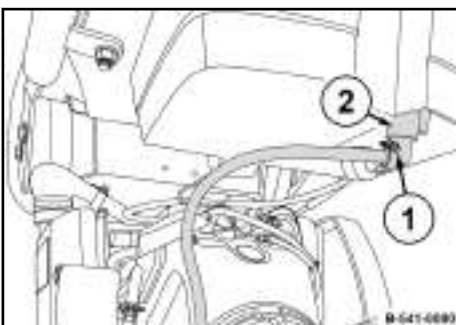

Fig. 90

10. Connect the fuel hose with the hose clamp (1) to the fuel valve (2).

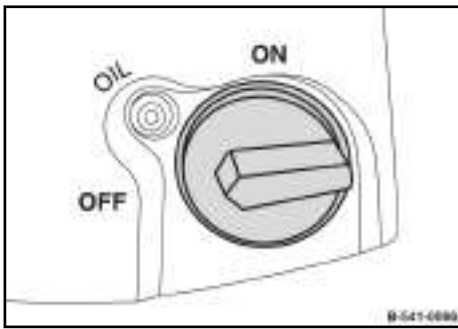

Fig. 91

11. Close the fuel valve (engine stop switch in position "OFF").
12. Dispose of fuel environmentally.

### 8.9.5 Replacing the air filter



#### NOTICE!

#### Danger of engine damage!

- Do not start the engine after having removed the air filter.

- Protective equipment:
- Working clothes
  - Safety shoes
  - Protective gloves

1. Park the machine safely ↗ *Chapter 6.4 „Parking the machine in secured condition“ on page 53.*
2. Allow the engine to cool down.
3. Disassemble the cover (1) and air filter (2).
4. Clean the cover.
5. Replace the air filter.
6. Insert the air filter and reassemble the cover.

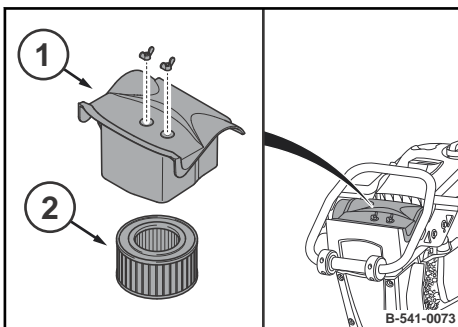

Fig. 92

## Maintenance – Annually

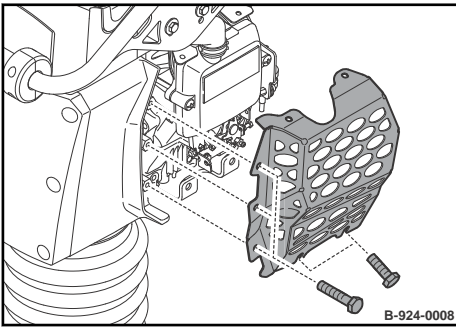

Fig. 93

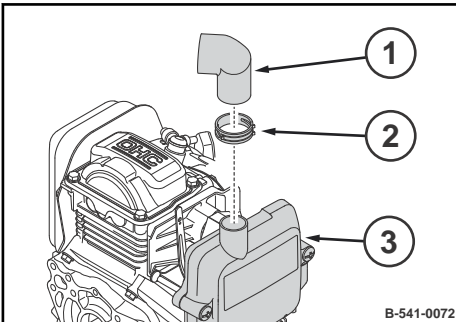

Fig. 94

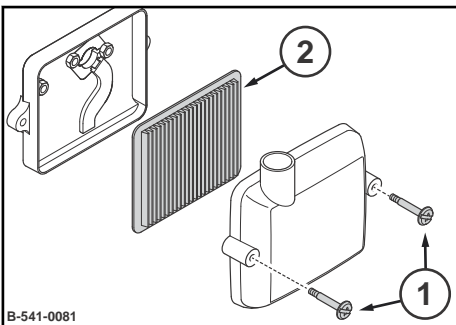

Fig. 95

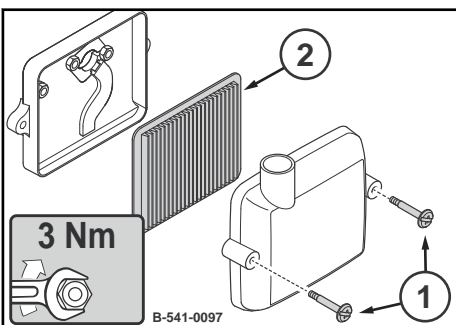

Fig. 96

7. Disassemble the left engine guard.

8. Pull the air feed hose (1) and the hose clamp (2) off the cover (3).

9. Unscrew the fastening screws (1).

10. Disassemble the cover and air filter (2).

11. Wipe the inside of the air filter housing with a clean cloth.

12. Replace the air filter.

13. Slide the air filter (2) carefully into the housing.

14. Assemble the cover with fastening screws (1), tightening torque: 3 Nm (2 ft·lbf).

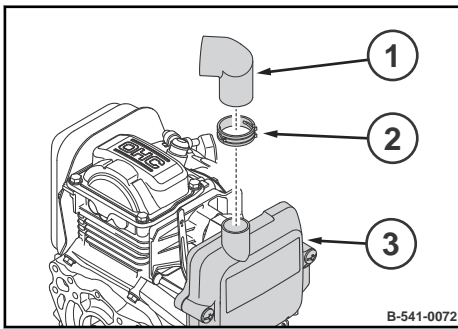

Fig. 97

15. Connect the air hose (1) with the hose clamp (2) to the cover (3).

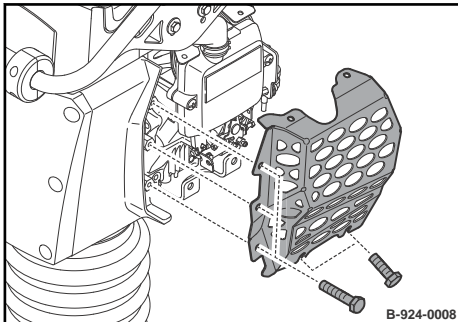

Fig. 98

16. Assemble the left engine guard.

### 8.9.6 Checking, adjusting the engine speed

#### 8.9.6.1 Checking the engine speed

##### Preparations

1. Replace the air filter ↪ *Chapter 8.9.5 „Replacing the air filter“ on page 85.*
2. Check the engine oil level ↪ *Chapter 5.3 „Checking the engine oil level“ on page 42.*

##### Checking the engine speed

Protective equipment: ■ Hearing protection  
■ Safety shoes



#### CAUTION!

**Danger of injury caused by uncontrolled machine movement!**

- Keep your feet clear of the tamper foot plate.
- Always hold on to a running machine.
- Always keep an eye on a running machine.



#### WARNING!

**Loss of hearing caused by too high noise burdens!**

- Wear your personal protective equipment (ear protection).

## Maintenance – Annually

### Nominal values:

Idle speed	1850 to 2000 min <sup>-1</sup>
Maximum engine speed	3850 to 4200 min <sup>-1</sup>

1. Start the engine and run it warm for approx. 15 minutes.
2. Run the machine on ground that can be compacted.
3. Set the throttle lever to position “MIN”.

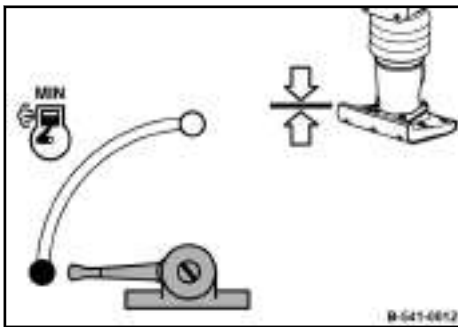

Fig. 99

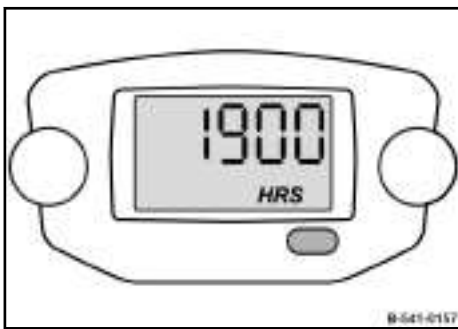

Fig. 100

4. After approx. 30 to 40 seconds read the idle speed from the engine rpm-meter.

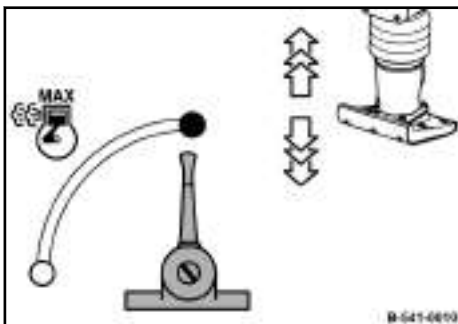

Fig. 101

5. Set the throttle lever to “MAX” position.
6. After approx. 30 to 40 seconds read the max. speed from the engine rpm-meter.
7. If necessary, adjust the idle speed or maximum speed as required.

### 8.9.6.2 Adjusting the engine speed

Protective equipment: ■ Working clothes  
 ■ Safety shoes  
 ■ Protective gloves

1. Park the machine safely ↪ *Chapter 6.4 „Parking the machine in secured condition“ on page 53.*
2. Disassemble the left engine guard.

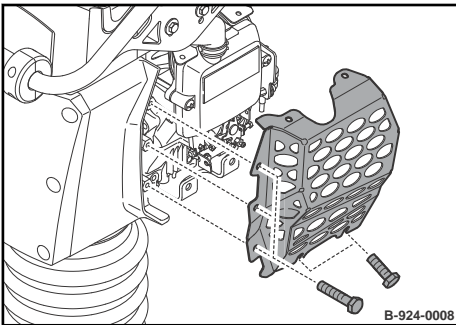

Fig. 102

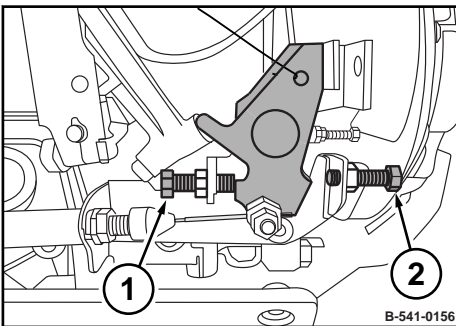

Fig. 103

3.



#### WARNING!

#### Danger of burning on hot components!

- Wear your personal protective equipment (protective gloves, protective clothing).
- Avoid touching hot components.

Adjust the idle speed using the stop screw (2) on the throttle lever.

4. Adjust the maximum speed via the stop screw (1).
5. Secure the stop screws with counter nuts.



*Adjust the throttle cable, if this should be necessary.*

6. Assemble the left engine guard.

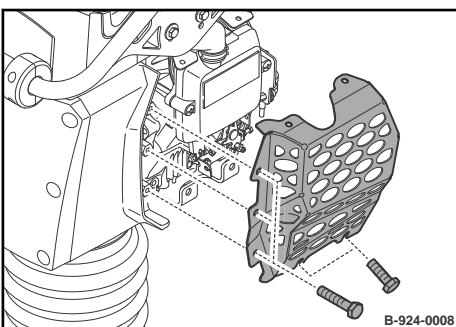

Fig. 104

### 8.9.7 Replacing the starter rope

Protective equipment: ■ Working clothes  
■ Protective gloves

1. Park the machine in secured condition ↗ *Chapter 6.4 „Parking the machine in secured condition“ on page 53.*
2. Allow the engine to cool down.
3. Disassembling the recoil starter.

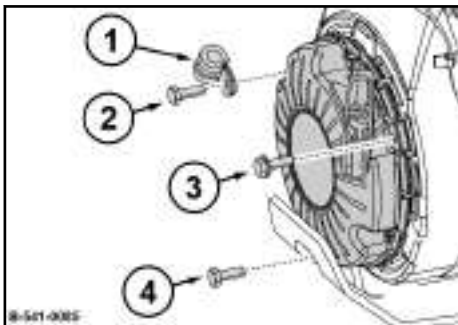

Fig. 105

- 1 Pipe clamp
- 2 Screw M6x18
- 3 Screw M6x14
- 4 Screw M6x18



Fig. 106

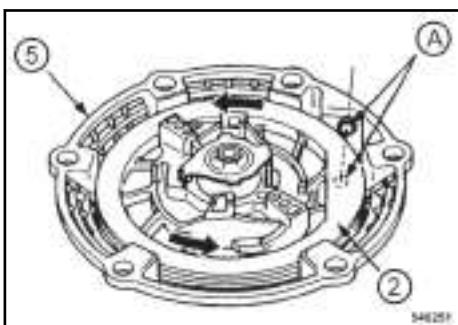

Fig. 107

4. Pull the starter rope with the starter handle out completely.

5. If the starter rope has been torn or the coil has recoiled completely:
  - Before assembling the rope, turn the coil (2) 5 revolutions in anti-clockwise direction and align the rope openings in coil and housing (5) to one another (A).

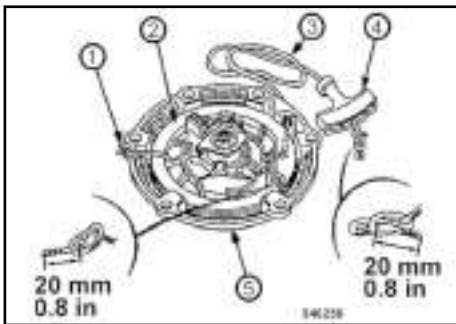

Fig. 108

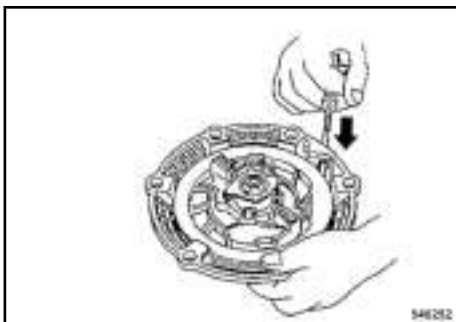

Fig. 109

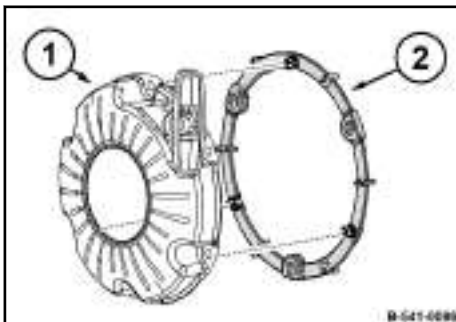

Fig. 110

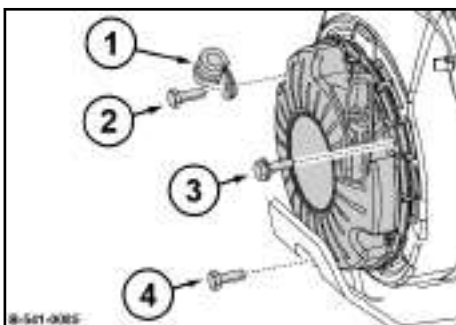

Fig. 111

- 1 Pipe clamp
- 2 Screw M6x18
- 3 Screw M6x14

6. Secure the coil against winding up. For this purpose tie the coil (2) to the housing (5) with a cable strap (1).
7. Untie the knots of the starter rope at both ends and remove the old starter rope.
8. Thread in the new starter rope (3) and fix it with knots on both ends.

9.



### CAUTION!

**Danger of injury caused by the starter handle hitting against your body!**

- Do not let the starter handle hit back.

Remove the fixing of the coil and run the starter handle slowly back to initial position.

10. Pull the starter handle to check the function and light movement of the recoil starter.

11. Clip in the spacer ring (2) on the recoil starter (1).

12.



### NOTICE!

**The recoil starter may get damaged!**

- Do not mix up the fastening screws for the recoil starter by mistake.

Assemble the recoil starter.

4 Screw M6x18

### 8.9.8 Changing the oil in the rammer foot



#### NOTICE!

##### Components may get damaged!

- Drain tamper foot oil only at operating temperature.
- Ensure strict cleanliness.
- Use only tamper oil of the permitted specification.
- Filling quantity: ↪ *Chapter 8.3 „List of fuels and lubricants“ on page 65.*

Protective equipment: ■ Working clothes  
■ Safety shoes  
■ Protective gloves



#### WARNING!

##### Danger of burning on hot components!

- Wear your personal protective equipment (protective gloves, protective clothing).
- Avoid touching hot components.

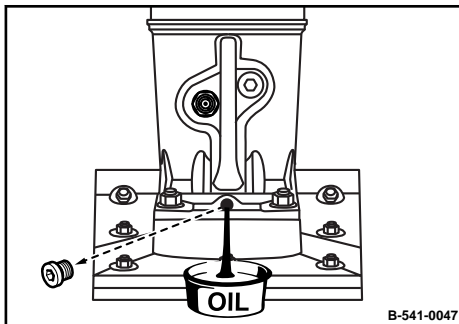

Fig. 112

1. Park the machine safely ↪ *Chapter 6.4 „Parking the machine in secured condition“ on page 53.*
2. Clean the area around filler and drain plug.
3. Unscrew the drain plug, tilt the machine backward and collect running out oil.
4. Stand the machine on its foot again and secure it against tipping over.
5. Clean the drain plug and screw it in with sealing agent (low-strength, e.g. spare parts number DL 009 700 16).

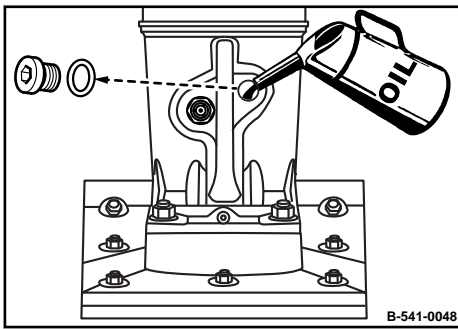

Fig. 113

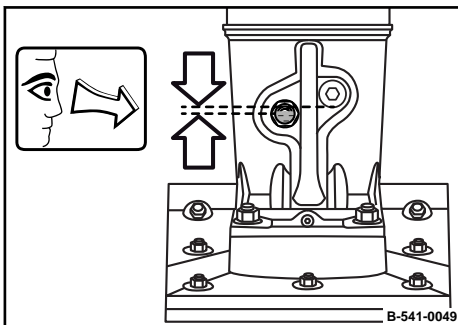

Fig. 114

7. Fill in fresh oil up to the bottom edge of the filler bore.
8. Clean the filling plug and screw it back in with a new seal ring.

10. Check the oil level in the inspection glass, correct if necessary.



*The upper edge of the inspection glass equals the bottom edge of the oil filling bore.*

11. Dispose of oil in line with environmental regulations.

### 8.10 As required

#### 8.10.1 Cleaning the machine



#### NOTICE!

#### Danger of engine damage caused by reduced cooling!

- Immediately remove any oil or fuel leaks near fuel tank, cylinders or cooling air intake.

Protective equipment: ■ Working clothes  
■ Safety shoes  
■ Protective gloves

1. Park the machine safely ↪ *Chapter 6.4 „Parking the machine in secured condition“ on page 53.*
2. Allow the engine to cool down.



#### NOTICE!

#### Components can be damaged by water entering into the system!

- Do not guide the water jet directly into the air intake and the recoil starter .

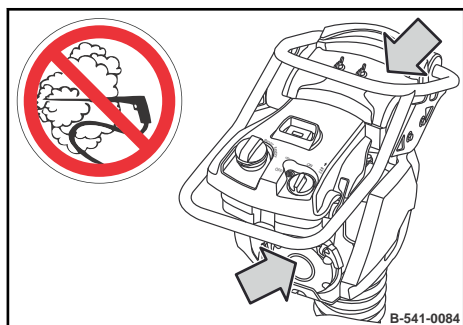

Fig. 115

3. Clean the machine with a water jet.
4. Warm up the engine for a while to avoid corrosion.

#### 8.10.2 Checking, cleaning the spark plug



#### NOTICE!

#### Danger of engine damage!

- Do not use spark plugs with incorrect heat value.

Protective equipment: ■ Working clothes  
 ■ Protective gloves

Special tool: ■ 16 mm spark plug spanner

1. Park the machine in secured condition ↪ *Chapter 6.4 „Parking the machine in secured condition“ on page 53.*
2. Allow the engine to cool down for at least 15 minutes.
3. Pull off the spark plug connector (1).
4. Clean the area around the spark plug.
5. Unscrew the spark plug with a 16 mm spark plug spanner (2).

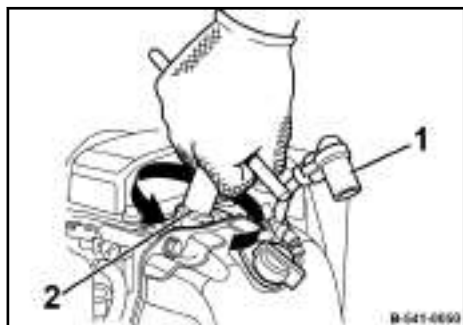

Fig. 116

6. Check the condition of the spark plug, clean if necessary.
7. In case of excessive combustion residues or burned off electrodes, replace the spark plug ↪ *Chapter 8.9.2 „Replacing the spark plug“ on page 79.*
8. Check the electrode gap of the spark plug with a feeler gauge, if necessary, adjust the gap.  
 ⇒ **Nominal value:** 0.6 - 0.7 mm (0.024 - 0.028 in)
9. Carefully screw in the spark plug by hand.
10. Once the sealing surface of the used spark plug is in contact, tighten for another 1/8 to 1/4 turn with the spark plug spanner.

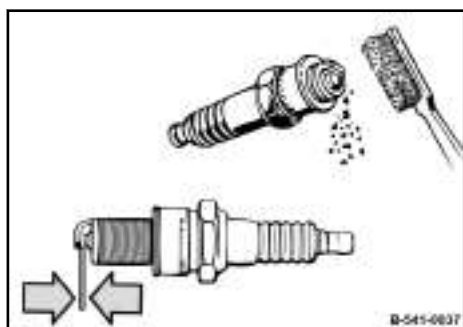

Fig. 117





### 9.1 Changing the tamper foot plate



Only use genuine spare parts when changing the tamper foot plate to a different width.

Protective equipment: ■ Protective gloves  
■ Working clothes

1. Park the machine in secured condition ↪ *Chapter 6.4 „Parking the machine in secured condition“ on page 53.*
2. Allow the machine to cool down.
3. Lay the machine carefully on the rollers.

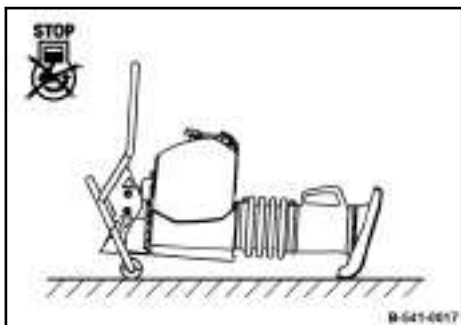

Fig. 118

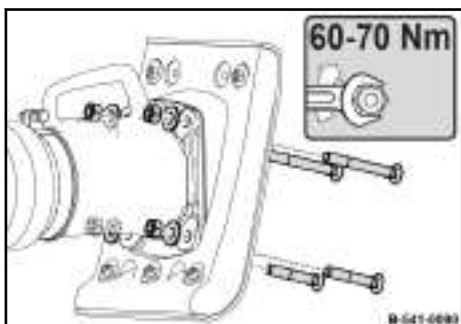

Fig. 119

4. Unscrew the fastening screws.
5. Take off the tamper foot plate and lay the tamper foot on the floor.
6. Fasten the new tamper foot plate with the fastening screws, tightening torque: 60 bis 70 Nm (44 bis 52 ft·lbf).
7. Check the engine speed, readjust if necessary ↪ *Chapter 8.9.6 „Checking, adjusting the engine speed“ on page 87.*



### 10.1 Preliminary remarks

Malfunctions are frequently caused by incorrect operation of the machine or insufficient maintenance. Whenever a fault occurs you should therefore thoroughly read these instructions on correct operation and maintenance.

If you cannot locate the cause of a fault or rectify it yourself by following the trouble shooting chart, you should contact our customer service department.

## 10.2 Engine faults

Fault	Possible cause	Remedy
Engine does not start	Fuel tank empty	Check, fill up if necessary
	Fuel system clogged	Clean the fuel screen in the tank Replacing the fuel filter
		Check the fuel screen in the carburettor Have checked by qualified expert personnel
		Set the engine stop switch to position "OFF"
	Engine oil level too low (The engine oil level warning lamp lights)	Check the engine oil level, correct if necessary
	No ignition spark	Clean the spark plug, replace if necessary
		Check the ignition coil Have checked by qualified expert personnel
	Engine stop switch defective	Have checked by qualified expert personnel
No fuel in carburettor	Check the fuel supply Have checked by qualified expert personnel	
Engine does not crank when operating the recoil starter	Recoil starter defective	Replace the recoil starter
	Spring broken	Replace the recoil starter
Starter rope of recoil starter does not return to initial position	Recoil starter dirty	Clean the recoil starter
	Insufficient pre-tension of the spring	Check the pre-tension of the spring, adjust if necessary
	Spring broken	Replace the recoil starter
Engine stops frequently in short intervals	Fuel system clogged	Clean the fuel screen in the tank Replacing the fuel filter
		Check the fuel screen in the carburettor Have checked by qualified expert personnel
		Tank lid ventilation defective
	Poor fuel quality	Check the fuel quality, if necessary change the fuel
Engine does not run with full speed	Throttle cable defective	Have checked by qualified expert personnel

## Troubleshooting – Engine faults

Fault	Possible cause	Remedy
	Throttle cable incorrectly adjusted	Have checked by qualified expert personnel
	Air filter clogged	Clean the air filter, replace if necessary
	Engine oil level too high	Check the engine oil level, if necessary drain off engine down to the "MAX" mark
		Clean the air intake Have checked by qualified expert personnel
	Exhaust blocked	Clean the exhaust
	Engine defective	Have checked by qualified expert personnel
	Carburettor defective	Have checked by qualified expert personnel
Engine runs irregularly	Basic setting of governor arm de-adjusted	Have checked by qualified expert personnel
Insufficient engine power	Spark plug defective	Check the spark plug, replace if necessary
	Incorrect valve clearance	Check, adjust if necessary
	Valve or valve seat worn or damaged	Have checked by qualified expert personnel
	Cylinder, piston or piston rings worn	Have checked by qualified expert personnel
Engine runs with high speed, but no vibration	Centrifugal clutch defective	Have checked by qualified expert personnel
	Mechanical defect	Have checked by qualified expert personnel

### 10.3 What to do if the engine has flooded



#### WARNING!

Loss of hearing caused by too high noise burdens!

- Wear your personal protective equipment (ear protection).

Protective equipment: ■ Hearing protection  
■ Safety shoes

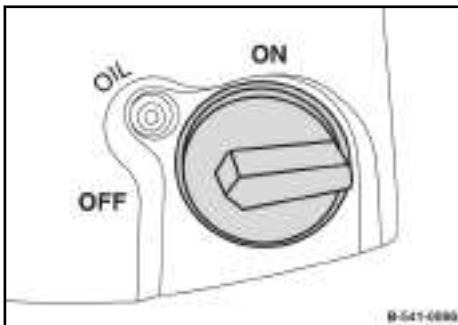

Fig. 120

1. Set the engine stop switch to position "OFF".

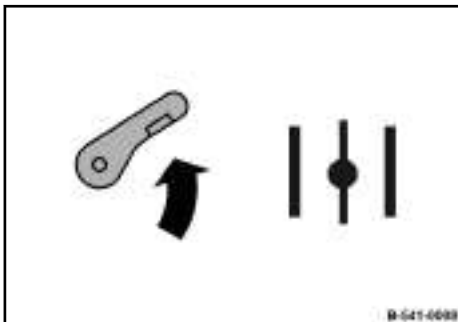

Fig. 121

2. Open the choke.

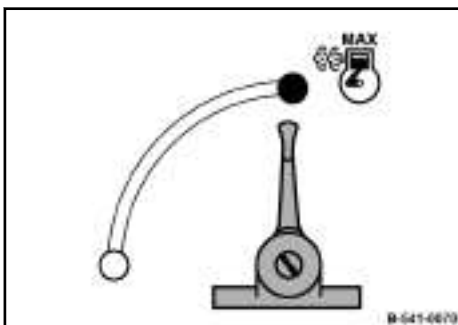

Fig. 122

3. Set the throttle lever to position "MAX".

## Troubleshooting – What to do if the engine has flooded

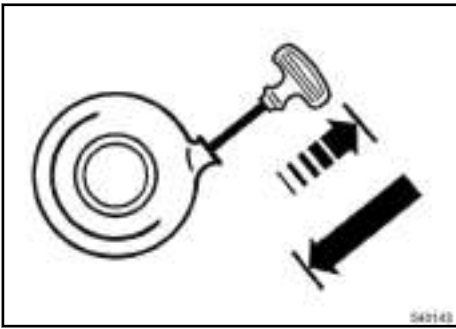

Fig. 123

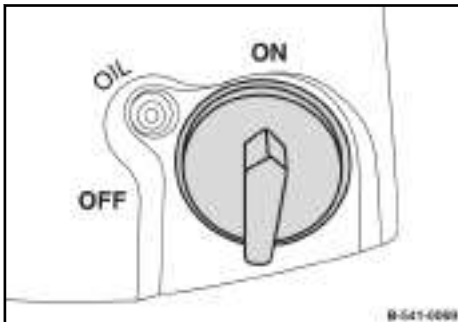

Fig. 124

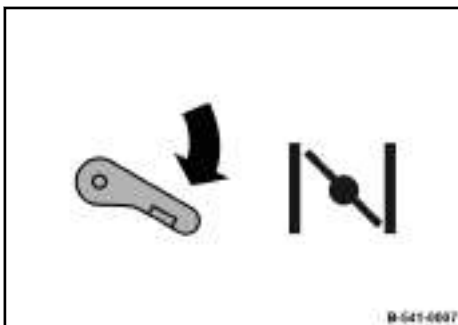

Fig. 125

4. Operate the recoil starter 10 to 20 times.

5. Set the engine stop switch to position "ON".

- 6.



### CAUTION!

**Danger of injury caused by uncontrolled machine movement!**

- Always hold on to a running machine.
- Always keep an eye on a running machine.

Operate the recoil starter once again.

7. If the engine does not start after 3 to 5 attempts, close the choke and operate the recoil starter once again.
8. If the engine still does not start after 3 to 5 attempts, clean the spark plug.

## Troubleshooting – What to do if the engine has flooded

### Cleaning the spark plug

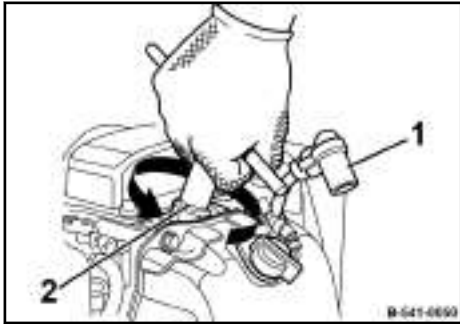

Fig. 126

Protective equipment: ■ Working clothes  
■ Protective gloves  
■ Safety goggles

Special tool: ■ 16 mm spark plug spanner

1. Pull off the spark plug socket (1).
2. Unscrew the spark plug with a 16 mm spark plug spanner (2).
3. Operate the recoil starter several times.
- 4.



#### CAUTION!

**Danger of eye injuries caused by particles flying around!**

- Wear your personal protective equipment (safety gloves, protective working clothes, goggles).

Dry the spark plug with a clean cloth or blow it dry with compressed air.

5. If necessary, clean the spark plug with a wire brush.
6. Screw the spark plug carefully in by hand and once the sealing surface of the used spark plug is in contact tighten for another 1/8 to 1/4 turn with the spark plug spanner.
7. Plug the spark plug socket back on.
8. Repeat the starting procedure.





### 11.1 Final shut-down of machine

If the machine can no longer be used and needs to be finally shut down you must carry out the following work and have the machine disassembled by an officially recognized specialist workshop.



#### **DANGER!**

#### **Danger to life caused by explosive gas-air mixes!**

- Do not allow gasoline to come into contact with hot components.
- Smoking and open fire is prohibited.
- Keep gasoline away from heat sources, sparks and other sources of ignition.
- Do not spill any gasoline.
- Components that previously contained gasoline must not be cut with a cutting torch.



#### **WARNING!**

#### **Health hazard caused by fuels and lubricants!**

- Safety regulations and environmental protection regulations must be followed when handling fuels and lubricants ↪ *Chapter 3.4 „Handling fuels and lubricants“ on page 23.*

Protective equipment: ■ Working clothes  
■ Safety shoes  
■ Protective gloves  
■ Safety goggles

1. Empty the fuel tank.
2. Drain oil from engine and tamper foot.



