

Operating Instruction/Maintenance Instruction

Original Operating Instructions

DFP11

Forward plate



S/N 101 924 24 1001>
DL820351EN
© 02/2020

 **WARNING:** Breathing diesel engine exhaust exposes you to chemicals known to the State of California to cause cancer and birth defects or other reproductive harm.

- Always start and operate the engine in a well-ventilated area.
- If in an enclosed area, vent the exhaust to the outside.
- Do not modify or tamper with the exhaust system.
- Do not idle the engine except as necessary.

For more information go to www.P65warnings.ca.gov/diesel.

 **WARNING:** Crude oil, gasoline, diesel fuel and other petroleum products can expose you to chemicals including toluene and benzene, which are known to the State of California to cause cancer and birth defects or other reproductive harm.

These exposures can occur in and around oil fields, refineries, chemical plants, transport and storage operations such as pipelines, marine terminals, tank trucks and other facilities and equipment.

For more information go to www.P65Warnings.ca.gov/petroleum.

Table of contents

1	Introduction	7
	1.1 Foreword	8
	1.2 Machine type plate and engine type plate	10
2	Technical data	11
	2.1 Noise and vibration data	14
	2.1.1 Noise data.....	14
	2.1.2 Vibration data.....	14
3	Concerning your safety	15
	3.1 Basic prerequisites	16
	3.1.1 General.....	16
	3.1.2 Explanation of signal words used:.....	16
	3.1.3 Personal protective equipment.....	17
	3.1.4 Intended use.....	18
	3.1.5 Improper use.....	18
	3.1.6 Estimated service life of the machine.....	19
	3.2 Definition of responsible persons	20
	3.2.1 Operating company.....	20
	3.2.2 Expert / qualified person.....	20
	3.2.3 Driver / operator.....	20
	3.3 Basic safety regulations for safe operation	22
	3.3.1 Remaining dangers, remaining risks.....	22
	3.3.2 Regular safety inspections.....	22
	3.3.3 Modifications and alterations to the machine.....	22
	3.3.4 Damage, defects, misuse of safety devices.....	22
	3.4 Handling fuels and lubricants	23
	3.4.1 Preliminary remarks.....	23
	3.4.2 Safety regulations and environmental protection regulations for handling gasoline.....	24
	3.4.3 Safety regulations and environmental protection regulations for handling fuel stabiliser.....	25
	3.4.4 Safety regulations and environmental protection regulations for handling oil.....	26
	3.5 Loading/transporting the machine	27
	3.6 Start up procedure	28
	3.6.1 Prior to starting up.....	28
	3.6.2 Spark protection.....	28
	3.6.3 Starting the engine.....	28
	3.7 Operation	30
	3.7.1 Persons in the danger area.....	30
	3.7.2 Operation.....	30
	3.7.3 Parking the machine.....	30
	3.8 Refuelling	31
	3.9 Maintenance work	32
	3.9.1 Preliminary remarks.....	32
	3.9.2 Working on the engine.....	32
	3.9.3 Cleaning work.....	32
	3.9.4 After maintenance work.....	32

Table of contents

3.10	Repair.....	33
3.11	Signage.....	34
3.12	Safety components.....	39
4	Indicators and control elements.....	41
4.1	Engine.....	42
4.1.1	Overview.....	42
4.1.2	Engine stop switch.....	42
4.1.3	Throttle lever.....	43
4.1.4	Choke lever.....	43
4.1.5	Recoil starter.....	43
4.1.6	Fuel valve.....	44
4.2	Water spraying system.....	45
4.2.1	Rotary button for water sprinkling system.....	45
4.3	Transport wheels.....	46
4.3.1	Transport wheels with guide handle in middle position.....	47
5	Checks prior to start up.....	49
5.1	Notes on safety.....	50
5.2	Visual inspections and function tests.....	51
5.3	Checking the engine oil level.....	52
5.4	Checking the fuel level; topping up fuel.....	53
5.5	Checking the rubber buffers.....	54
5.6	Checking the water level, topping up.....	55
6	Operation.....	57
6.1	Mounting the guide handle.....	58
6.2	Starting the engine.....	59
6.3	Operation.....	62
6.4	Switching the water sprinkling system on/off.....	64
6.5	Parking the machine in secured condition.....	65
7	Loading/transporting the machine.....	67
7.1	Loading the machine.....	68
7.2	Lashing the machine to the transport vehicle.....	70
7.3	Transport wheels.....	71
7.3.1	Transport wheels with guide handle in middle position.....	72
8	Maintenance.....	73
8.1	Preliminary remarks and safety notes.....	74
8.2	Fuels and lubricants.....	75
8.2.1	Engine oil.....	75
8.2.2	Fuel.....	75
8.2.3	Oil for exciter shaft housing.....	76
8.3	List of fuels and lubricants.....	77
8.4	Running-in instructions.....	78
8.4.1	General.....	78
8.4.2	After 25 operating hours.....	78
8.5	Maintenance Table.....	79
8.6	Weekly.....	80

8.6.1	Checking, cleaning the air filter.....	80
8.7	Semi-annually.....	83
8.7.1	Changing the engine oil.....	83
8.8	Annually.....	84
8.8.1	Replacing the spark plug.....	84
8.8.2	Checking, adjusting the valve clearance.....	84
8.8.3	Cleaning the slurry filter and fuel strainer.....	86
8.8.4	Replacing the V-belt.....	89
8.8.5	Replacing the starter rope.....	91
8.8.6	Changing the oil in the exciter housing.....	93
8.8.7	Replacing the air filter.....	94
8.9	As required.....	96
8.9.1	Cleaning the cooling fins and the cooling air intake openings.....	96
8.9.2	Cleaning the machine.....	97
8.9.3	Cleaning the water spraying system.....	98
8.9.4	Servicing the V-belt.....	98
8.9.5	Checking, cleaning the spark plug.....	99
8.9.6	Measures prior to extended shut-down period.....	100
9	Troubleshooting.....	103
9.1	Preliminary remarks.....	104
9.2	Engine malfunctions.....	105
9.3	What to do if the engine has flooded.....	107
10	Disposal.....	109
10.1	Final shut-down of machine.....	110

1.1 Foreword

These operating and maintenance instructions are part of your machine.

They provide necessary information to operate your machine safely and properly.

They also contain information on required operating, maintenance and repair measures.

Carefully read the operating and maintenance instructions before taking your machine into operation.

Please observe the safety regulations strictly and follow all instructions to ensure safe operation.

If you are not yet acquainted with the indicators and control elements on this machine, you should thoroughly read the corresponding chapter ↪ *Chapter 4 'Indicators and control elements' on page 41.*

The description of the individual operating steps including the notes on safety to be followed can be found in chapter "Operation" ↪ *Chapter 6 'Operation' on page 57.*

Before every start up, carry out all required visual inspections and function tests ↪ *Chapter 5 'Checks prior to start up' on page 49.*

Ensure the compliance with the specified operating, maintenance and repair measures to maintain the functional safety of your machine.

A description of all necessary maintenance work, maintenance intervals as well as information on fuels and lubricants can be found in the chapter "Maintenance" ↪ *Chapter 8 'Maintenance' on page 73.*

Do not service or repair your machine by yourself to avoid harming persons or damaging material or environment.

The machine must only be serviced and repaired by qualified and authorised personnel.

Contact our customer service to carry out the required maintenance work or necessary repairs.

In case of operating errors, inadequate maintenance or the use of unapproved fuels and lubricants all warranty claims will become null and void.

For your own personal safety you should only use original parts from Dynapac.

For your machine we offer service kits to make maintenance easier.

In the course of technical development we reserve the right for technical modifications without prior notification.

These operating and maintenance instructions are also available in other languages.

Apart from that, you can also order the spare parts catalogue against the serial number of your machine.

The above notes do not constitute an extension of the warranty and liability conditions specified in the general sales and delivery conditions of Dynapac GmbH.

We wish you successful work with your Dynapac machine.

1.2 Machine type plate and engine type plate

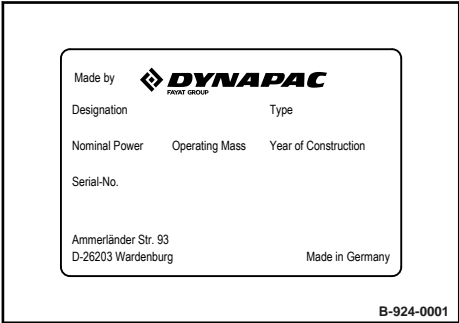

Fig. 1: Machine type plate (example)

Please enter here:	
Machine type (1):	
Serial number (2):	

Engine type and engine number

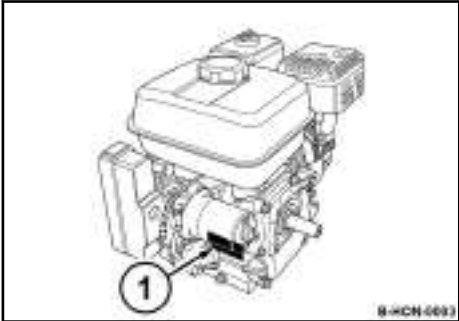
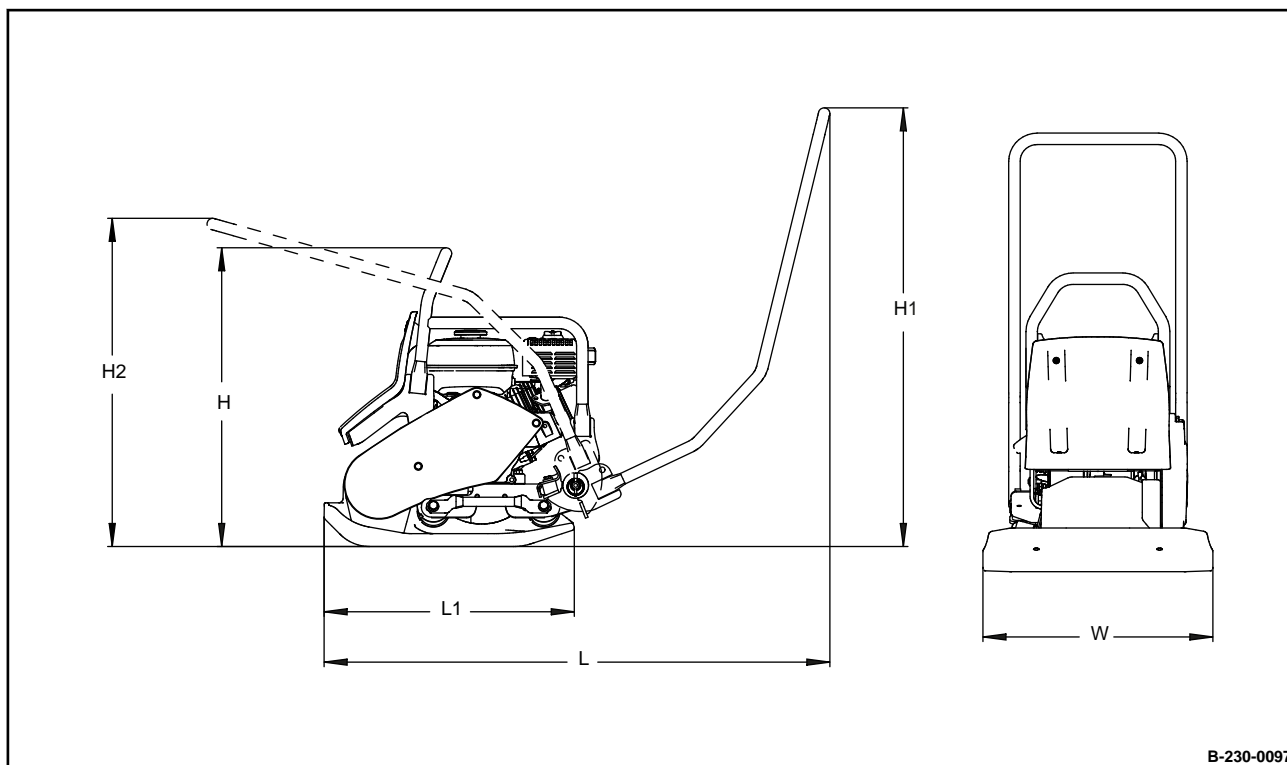

Fig. 2

Please enter here:	
Engine type:	
Engine number:	

Technical data

Dimensions



B-230-0097

Fig. 3

H	H ₁	H ₂	L	L ₁	W
658	962	700	1084	542	500
(25.9)	(37.9)	(27.6)	(42.7)	(21.3)	(19.7)

Dimensions in millimetres

(Dimensions in inch)

Weights		
Operating weight (CECE)	108	kg
	(238)	(lbs)
Basic weight	107	kg
	(236)	(lbs)
Water spraying system (<i>optional equipment</i>)	+ 10	kg
	(+ 22)	(lbs)
Transport wheels (<i>optional equipment</i>)	+ 4	kg
	(+ 8.8)	(lbs)

Technical data

Travel characteristics		
Max. working speed	30 (98)	m/min (ft/min)
Max. gradability (depending on soil)	30	%

Drive		
Engine manufacturer	Honda	
Type	GX 160	
Cooling	Air	
Number of cylinders	1	
Rated power SAE J 1349	3.6 (4.8)	kW (hp)
Rated speed	3600	min ⁻¹
Drive system	mechanical	

Exciter system		
Frequency	92 (5520)	Hz (vpm)
Centrifugal force	25 (5620)	kN (lbf)
Amplitude	1.75 (0,069)	mm (in)

Water sprinkling system (optional equipment)		
Type of sprinkling	Gravity feed	

Filling capacities		
Fuel (gasoline)	3.1 (0.8 each)	l (gal us)
Water sprinkling system	13.5 (3.6 each)	l (gal us)

2.1 Noise and vibration data

The following noise and vibration data were determined in accordance with the following guidelines under equipment specific conditions and by using harmonized standards:

- EU Machine Directive edition 2006/42/EU
- Noise Emission Directive 2000/14/EU, Noise Protection Directive 2003/10/EU
- Vibration Protection Directive 2002/44/EU

During operation these values may vary because of the prevailing operating conditions.

2.1.1 Noise data

Sound pressure level at the operator's stand

$L_{pA} = 95 \text{ dB(A)}$, determined acc. to ISO 11201 and EN 500.



WARNING!

Loss of hearing caused by too high noise burdens!

- Wear your personal protective equipment (ear protection).

Guaranteed sound power level

$L_{WA} = 108 \text{ dB(A)}$, determined acc. to ISO 3744 and EN 500.

2.1.2 Vibration data

Hand-arm vibration

Vector total of the weighted effective acceleration in three orthogonal directions:

Total vibration value $a_{hv} = 4.1 \text{ m/s}^2$ on crushed rock determined acc. to ISO 5349 and EN 500.

Associated uncertainty $K = 0.3 \text{ m/s}^2$, determined acc. to EN 12096.

Observe the daily vibration load (work safety acc. to 2002/44/EC).

Hand-arm vibration with comfort guide handle (optional equipment)

Vector total of the weighted effective acceleration in three orthogonal directions:

Total vibration value $a_{hv} \leq 2.5 \text{ m/s}^2$ on crushed rock determined acc. to ISO 5349 and EN 500.

Associated uncertainty $K = 0.1 \text{ m/s}^2$, determined acc. to EN 12096.

Observe the daily vibration load (work safety acc. to 2002/44/EC).

3.1 Basic prerequisites

3.1.1 General

This machine has been built in compliance with the latest technical standard and complies with the applicable regulations and technical rules.

However, dangers for persons and property may arise from this machine, if:

- it is used for purposes other than the ones it is intended for,
- it is operated by untrained personnel,
- it is changed or converted in an unprofessional way,
- the safety instructions are not observed.

Each person involved in the operation, maintenance and repair of the machine must therefore read and comply with these safety regulations. If necessary, the operating company must obtain the relevant signatures as confirmation.

Furthermore, the following obviously also applies:

- applicable accident prevention instructions,
- generally accepted safety and road traffic regulations,
- country/state specific safety regulations.

It is the duty of the operator to be acquainted with the safety regulations and to apply these accordingly. This also applies for local regulations and regulations concerning different types of handling activities. Should the recommendations in these instructions be different from the regulations valid in your country, you must comply with the safety regulations valid in your country.

3.1.2 Explanation of signal words used:



DANGER!

Danger to life if failing to comply!

Sections marked accordingly indicate an extremely dangerous situation that could lead to fatal or severe injuries, if this warning is disregarded.



WARNING!

Danger to life or danger of severe injuries if failing to comply!

Sections marked accordingly indicate a dangerous situation that could lead to fatal or severe injuries, if this warning is disregarded.

Concerning your safety – Basic prerequisites



CAUTION!

Danger of injury if failing to comply!

Sections marked accordingly indicate a dangerous situation that could lead to fatal or severe injuries, if this warning is disregarded.



NOTICE!

Danger of material damage if failing to comply!

Sections marked accordingly indicate possible dangers for machines or components.



Sections marked accordingly indicate technical information or notes on using the machine or its components.



ENVIRONMENT!

Environmental damage if failing to comply!





Paragraphs marked accordingly indicate practices for safe and environment-friendly disposal of fuels and lubricants as well as replacement parts.

3.1.3 Personal protective equipment

Depending on the work to be carried out, personal protective equipment is required (to be provided by the operating company):

	Working clothes	Tight fitting working clothes with low tear resistance, tight sleeves and without any projecting parts protect against being caught by moving components.
	Safety shoes	To protect against heavy falling parts and slipping on slippery ground.
	Protective gloves	To protect the hands against excoriation, punctures or deep injuries, against irritating and caustic substances as well as against burns.

Concerning your safety – Basic prerequisites

	Safety goggles	To protect the eyes against airborne particles and squirting fluids.
	Face protection	To protect the face against airborne particles and squirting fluids.
	Hard hat	To protect the head against falling parts and to protect against injuries.
	Hearing protection	To protect hearing against excessive noise.
	Respiratory protection	To protect respiratory tracts against substances or particles.

3.1.4 Intended use

This machine must only be used for:

- Compaction of all types of soils
- Repair work on all types of soil
- Paving of walkways
- Work in trenches
- Underfilling and compaction of hard shoulders

Intended use also includes compliance with the specified operating, maintenance and repair measures.

3.1.5 Improper use

Dangers may arise from the machine when it is used for purposes other than the one it is intended for.

Any danger caused by improper use is the sole responsibility of the operating company or driver/operator, the manufacturer cannot be made liable.

Examples for improper use are:

- dragging the machine along as a measure of transportation
- throwing the machine off the transport vehicle
- attaching an additional weight to the machine

It is not permitted to stand on the machine while working.

Lifting tackle must be removed before starting work.

Starting and operating the machine in explosive environments and in underground mining is prohibited.

The lifting and lashing points specified in these instructions must be used. It is prohibited to use other lifting and lashing points (e.g. guide handle, steering rod).

3.1.6 Estimated service life of the machine

If the following general conditions are met, the service life of the machine is usually in the range of several thousand operating hours:

- Regular safety inspections by an expert / qualified person
- Performance of the prescribed maintenance work within the specified time
- Immediate performance of necessary repair work
- Exclusive use of original spare parts

3.2 Definition of responsible persons

3.2.1 Operating company

The operating company is the natural or juridical person who uses the machine or in who's name the machine is used.

The operating company must make sure that the machine is only used for the purpose it is intended for and in strict compliance with the safety regulations mentioned in these operating and maintenance instructions.

The operating company must determine and assess the danger in its company. It must then take appropriate action to ensure health and safety at work for its employees and point out any remaining dangers.

The operating company must determine whether there are special operational hazards such as a toxic atmosphere or limiting soil conditions. Such conditions require special, additional measures to remove or reduce the hazard.

The operating company must make sure that all users read and understand the information concerning safety.

The operating company is responsible for the planning and professional execution of regular safety inspections.

3.2.2 Expert / qualified person

An expert / qualified person is a person who, based on his/her professional education and experience, has profound knowledge in the field of construction equipment and the machine in question in particular.

This person is acquainted with the applicable governmental industrial safety regulations, accident prevention instructions, guidelines and generally acknowledged technical rules and regulations (standards, directives, technical rules of other member states of the European Union or other contractual states concerning the agreement about the European Economic Area) in as far as is necessary to be able to judge the safe condition of this machine.

3.2.3 Driver / operator

This machine must only be operated by trained, instructed persons entrusted by the operating company aged 18 or more.

Observe your local laws and regulations.

Rights, obligations and rules of conduct for driver or operator:

The driver or operator must:

- be instructed about his rights and obligations,
- wear protective equipment as appropriate for the application,
- have read and understood the operating instructions,

Concerning your safety – Definition of responsible persons

- have made himself familiar with the operation of the machine,
- be physically and psychologically able to drive and operate the machine.

Persons under the influence of alcohol, medication or drugs are not allowed to operate, service or repair the machine.

Maintenance and repair work requires specific knowledge and must therefore only be performed by trained specialists.

3.3 Basic safety regulations for safe operation

3.3.1 Remaining dangers, remaining risks

Despite careful work and compliance with standards and regulations it cannot be ruled out that further dangers may arise when working with and handling the machine.

Both the machine as well as all other system components comply with the currently valid safety regulations. Nevertheless, remaining risks cannot be ruled out completely, even when using the machine for the purpose it is intended for and following all information given in the operating instructions.

A remaining risk can also not be excluded beyond the actual danger zone of the machine. Persons remaining in this area must pay particular attention to the machine, so that they can react immediately in case of a possible malfunction, an incident or failure etc.

All persons remaining in the area of the machine must be informed about the dangers that arise from the operation of the machine.

3.3.2 Regular safety inspections

Have the machine inspected by an expert / qualified person as required for the conditions the machine is working under, but at least once every year.

3.3.3 Modifications and alterations to the machine

Unauthorized changes to the machine are prohibited for safety reasons.

Original parts and accessories have been specially designed for this machine.

We wish to make explicitly clear that we have not tested or approved any parts or accessories not supplied by us.

The installation and/or use of such products may have an adverse effect on the active and/or passive safety.

3.3.4 Damage, defects, misuse of safety devices

Machines which are not safe to operate or in traffic must be immediately taken out of service and shall not be used, until these deficiencies have been properly rectified.

Safety installations and switches must neither be removed nor must they be made ineffective.

3.4 Handling fuels and lubricants

3.4.1 Preliminary remarks

The operating company must ensure that all professional users have read and follow the corresponding safety data sheets for the individual fuels and lubricants.

Safety data sheets provide valuable information about the following characteristics:

- name of substance
- possible dangers
- composition / information on constituents
- first-aid measures
- fire fighting measures
- measures in case of accidental release
- handling and storage
- limitation and monitoring of exposure / personal protective equipment
- physical and chemical properties
- stability and reactivity
- toxicological data
- environmental data
- notes on waste disposal
- information on transport
- legislation
- other data

3.4.2 Safety regulations and environmental protection regulations for handling gasoline

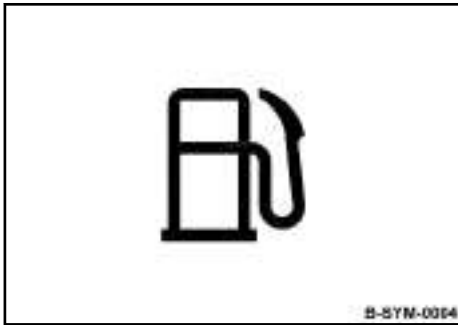

Fig. 4



DANGER!

Danger to life caused by explosive gas-air mixes!

- Do not allow gasoline to come into contact with hot components.
- Smoking and open fire is prohibited.
- Keep away from heat sources, sparks and other sources of ignition.
- Do not spill any gasoline.



WARNING!

Health hazard caused by contact with gasoline!

- Wear your personal protective outfit (protective gloves, protective clothing).
- Do not inhale any fuel fumes.
- Do not swallow gasoline.
- Avoid contact with gasoline.



ENVIRONMENT!

Gasoline is an environmentally hazardous substance!

- Always keep gasoline in proper containers.
- Immediately bind spilled gasoline with an oil-binding agent and dispose of in accordance with regulations.
- Dispose of gasoline and fuel filter according to regulations.

3.4.3 Safety regulations and environmental protection regulations for handling fuel stabiliser



WARNING!

Danger of burning by ignited fuel stabilizer!

- Do not allow fuel stabilizer to come into contact with hot components.
- Smoking and open fire is prohibited.



WARNING!

Health hazard caused by contact with fuel stabilizer!

- Wear your personal protective outfit (protective gloves, protective clothing).
- Do not inhale any fuel stabilizer fumes.
- Do not swallow fuel stabilizer.
- Avoid contact with fuel stabilizer.



ENVIRONMENT!

Fuel stabilizer is an environmentally hazardous substance!

- Immediately bind spilled fuel stabilizer with an oil-binding agent and dispose of according to regulations.
- Dispose of fuel stabilizer according to regulations.

3.4.4 Safety regulations and environmental protection regulations for handling oil

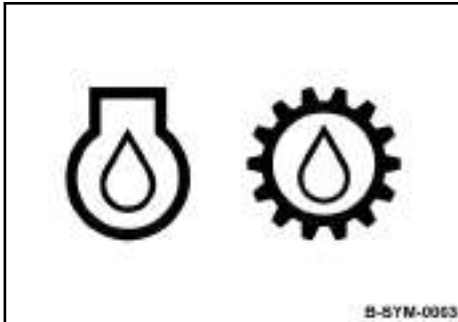

Fig. 5



WARNING!

Danger of burning by ignited oil!

- Do not allow oil to come into contact with hot components.
- Smoking and open fire is prohibited!
- Wear your personal protective equipment (protective gloves, protective clothing).



CAUTION!

Health hazard caused by contact with oil!

- Wear your personal protective equipment (protective gloves, protective clothing).
- Do not inhale any oil vapours.
- Avoid contact.



CAUTION!

Danger of slipping on spilled oil!

- Immediately bind spilled oil with an oil-binding agent.



ENVIRONMENT!

Oil is an environmentally hazardous substance!

- Always keep oil in proper containers.
- Immediately bind spilled oil with an oil-binding agent.
- Dispose of oil and oil filter according to regulations.

3.5 Loading/transporting the machine

Make sure that persons are not endangered by the machine tipping or sliding off.

Do not use damaged or in any other way impaired lashing points.

Always use appropriate lifting and lashing means on the lifting and lashing points.

Use lifting and lashing gear only in the prescribed direction of load application.

Lifting tackle must not be damaged by machine components.

Secure the machine on the transport vehicle against rolling, slipping and turning over.

Loads must only be attached and hoisted by an expert / capable person.

Use only lifting gear and lifting tackle with sufficient load bearing capacity for the weight to be loaded.

Fasten the lifting gear only at the specified lifting points.

Danger to the life of persons if they step or stand under a suspended load.

When lifting the machine avoid uncontrolled movements of the load. If necessary hold the load with guide ropes.

3.6 Start up procedure

3.6.1 Prior to starting up

Use only machines which are serviced at regular intervals.

Become acquainted with the equipment, the indicators and control elements, the working principle of the machine and the working area.

Use your personal protective equipment (hard hat, safety boots, if necessary also goggles and ear protection).

Do not take any loose objects with you or fasten them to the machine.

Before start up, check whether:

- persons or obstructions are beside or in front of the machine,
- the machine is free of oily and combustible materials,
- all safety elements are in place,
- all grips are free of grease, oils, fuel, dirt, snow and ice.

Before start up, carry out all required visual inspections and function tests.

If the following tests reveal damages or other faults, the machine must not be operated, until these deficiencies have been corrected.

Do not operate the machine with defective indicators and control elements.

3.6.2 Spark protection

The spark protection is optional.

In some areas of use operation of an engine without spark protection is not permitted.

Check the locally valid legislation and regulations.

3.6.3 Starting the engine

Do not use any starting aids like start pilot or ether.

The machine must not be operated with damaged, missing or non-functional safety installations.

Before starting and moving the machine make sure that there are no persons inside the danger zone.

Operate the machine only with the steering bow mounted and lowered.

Always keep an eye on the machine when the engine is running and hold it by the steering bow.

Do not inhale exhaust fumes, because they contain toxic substances, which could cause damage to health, unconsciousness or even death.

Concerning your safety – Start up procedure

Avoid operation in closed or partly closed rooms, or ensure adequate ventilation when working in trenches.

3.7 Operation

3.7.1 Persons in the danger area

Before taking up work, also after breaks, you should always convince yourself that the danger zone is free of persons or obstructions.

Give warning signals, if necessary. Stop work immediately if persons remain in the danger zone, despite the warning.

3.7.2 Operation

Guide the machine only by the guide handle.

Guide the machine so that your hands do not hit against solid objects.

Watch out for unusual noises and development of smoke. Perform trouble shooting and have the fault corrected.

Always keep a safe distance to excavation pit borders, embankments and edges.

Refrain from any work that could adversely affect the stability of the machine.

Observe the daily vibration load (work safety acc. to 2002/44/EC).

3.7.3 Parking the machine

Park the machine on horizontal, level, firm ground.

Before leaving the machine:

- Shut down the engine,
- Secure the machine against accidental tipping over,
- Secure the machine against unauthorized use.

Mark machines, which could be in the way, with a clearly visible sign.

3.8 Refuelling

Do not inhale any fuel fumes.

Refuel only with the engine shut down.

Do not refuel in closed rooms.

No open fire, do not smoke.

Keep away from ignition and heat sources.

Apply measures against electrostatic charging.

Do not spill any fuel. Collect leaking fuel, do not let it seep into the ground.

Wipe off spilled fuel. Keep dirt and water away from the fuel.

A leaking fuel tank can cause an explosion. Ensure tight fit of the cover; if necessary, replace immediately.

3.9 Maintenance work

3.9.1 Preliminary remarks

Always carry out the prescribed maintenance work and maintenance measures on time in order to maintain the safety, operational readiness and long service life of the machine.

The machine must only be serviced by qualified personnel authorised by the operating company.

3.9.2 Working on the engine

Drain the engine oil at operating temperature – danger of scalding!

Wipe off spilled oil, catch running out oil and dispose of environmentally.

When working on the air filter no dirt should fall into the air duct.

Do not work on the hot exhaust - danger of burning!

Store used filters and other oil contaminated materials in a separate, specially marked container and dispose of environmentally.

3.9.3 Cleaning work

Do not perform cleaning work while the motor is running.

Allow the engine to cool down before starting cleaning work.

Do not use gasoline or other easily inflammable substances for cleaning.

3.9.4 After maintenance work

Reassemble all guards and protections.

3.10 Repair

Identify a defect machine with a warning sign.

Only operate the machine after it has been repaired.

When replacing safety relevant components, only original spare parts must be used.

Repairs must only be performed by an expert/qualified person.

When performing welding work on the machine you should cover the fuel tank with insulating material.

Concerning your safety – Signage

3.11 Signage

Keep stickers and signage in good and legible condition and comply with their meaning.

Replace damaged and illegible stickers or signage immediately.

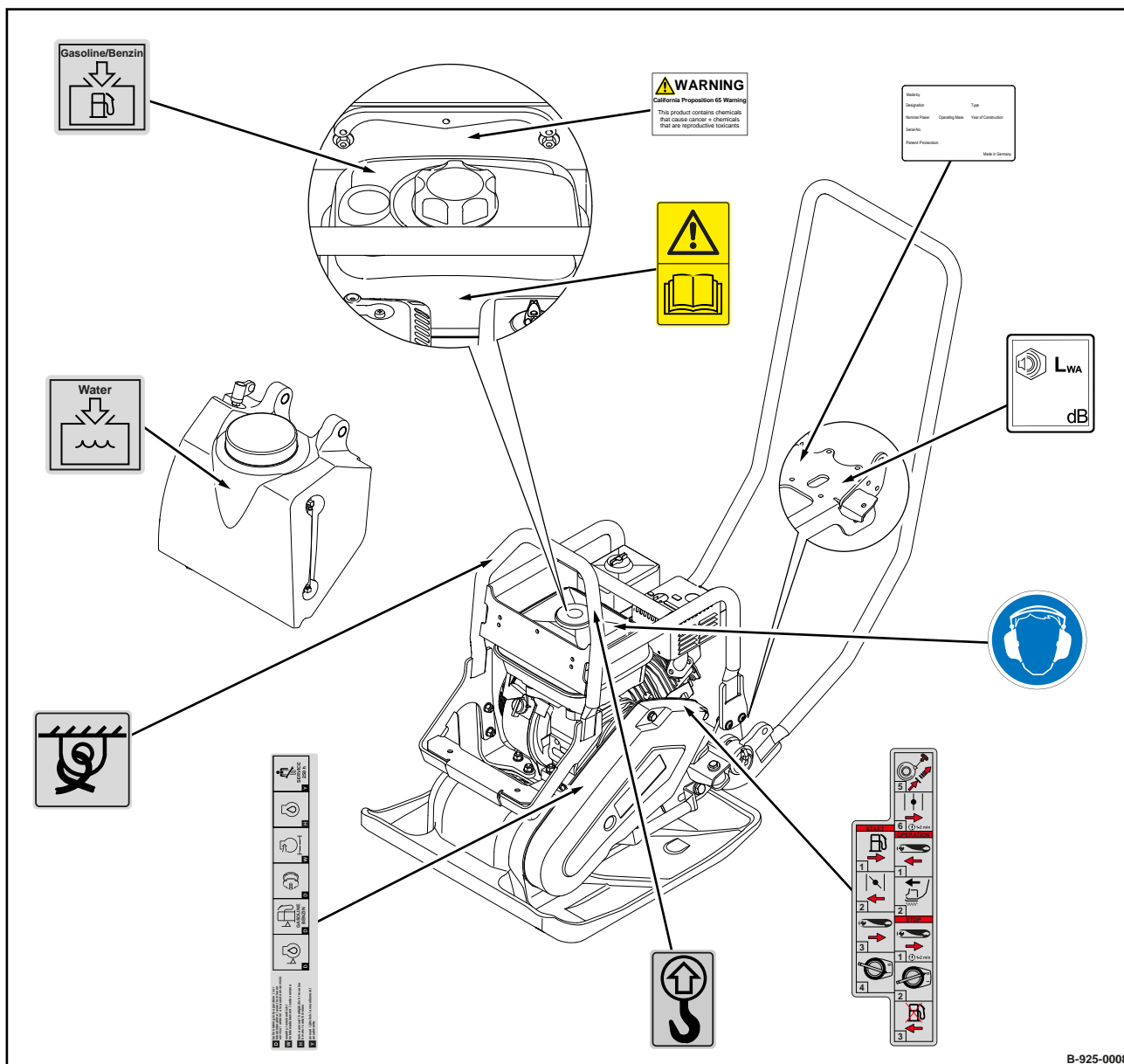

Fig. 6



Warning sticker - Follow operating instructions

Fig. 7



Warning sticker – California Proposition 65

Fig. 8



Instruction sticker - Wear ear defenders

Fig. 9



Information sticker - Lifting point

Fig. 10

Concerning your safety – Signage



Information sticker - Lashing point

Fig. 11

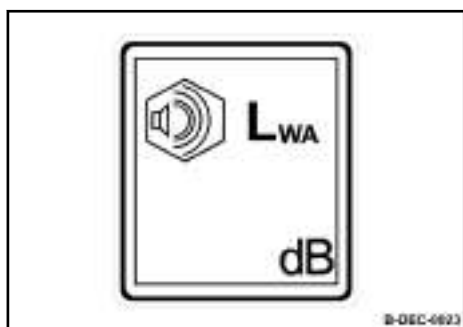

Information sticker - Guaranteed sound capacity level

Fig. 12

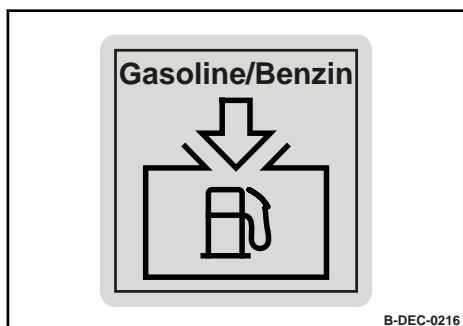

Information sticker - Filler opening for petrol

Fig. 13

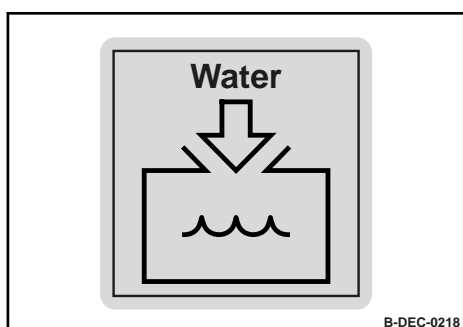

Information sticker - Filler opening for water

Fig. 14

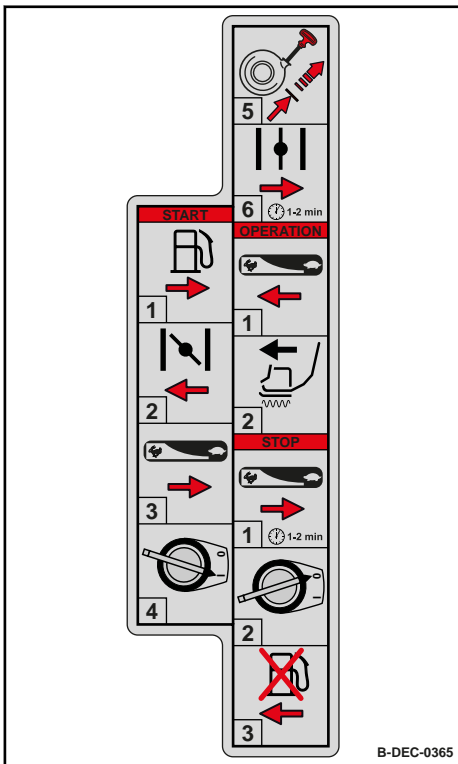

Brief operating instructions

Fig. 15

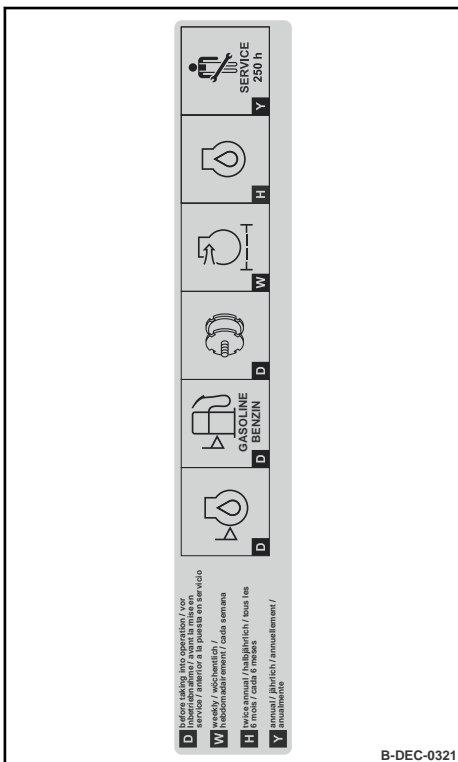

Maintenance sticker

Fig. 16

Concerning your safety – Signage

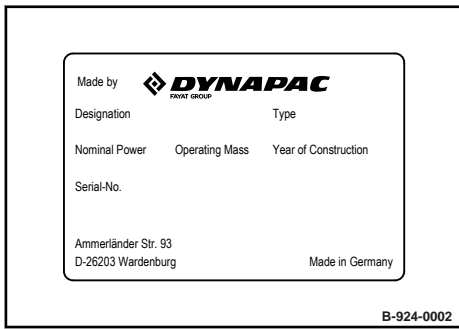

Machine type plate (example)

Fig. 17

3.12 Safety components

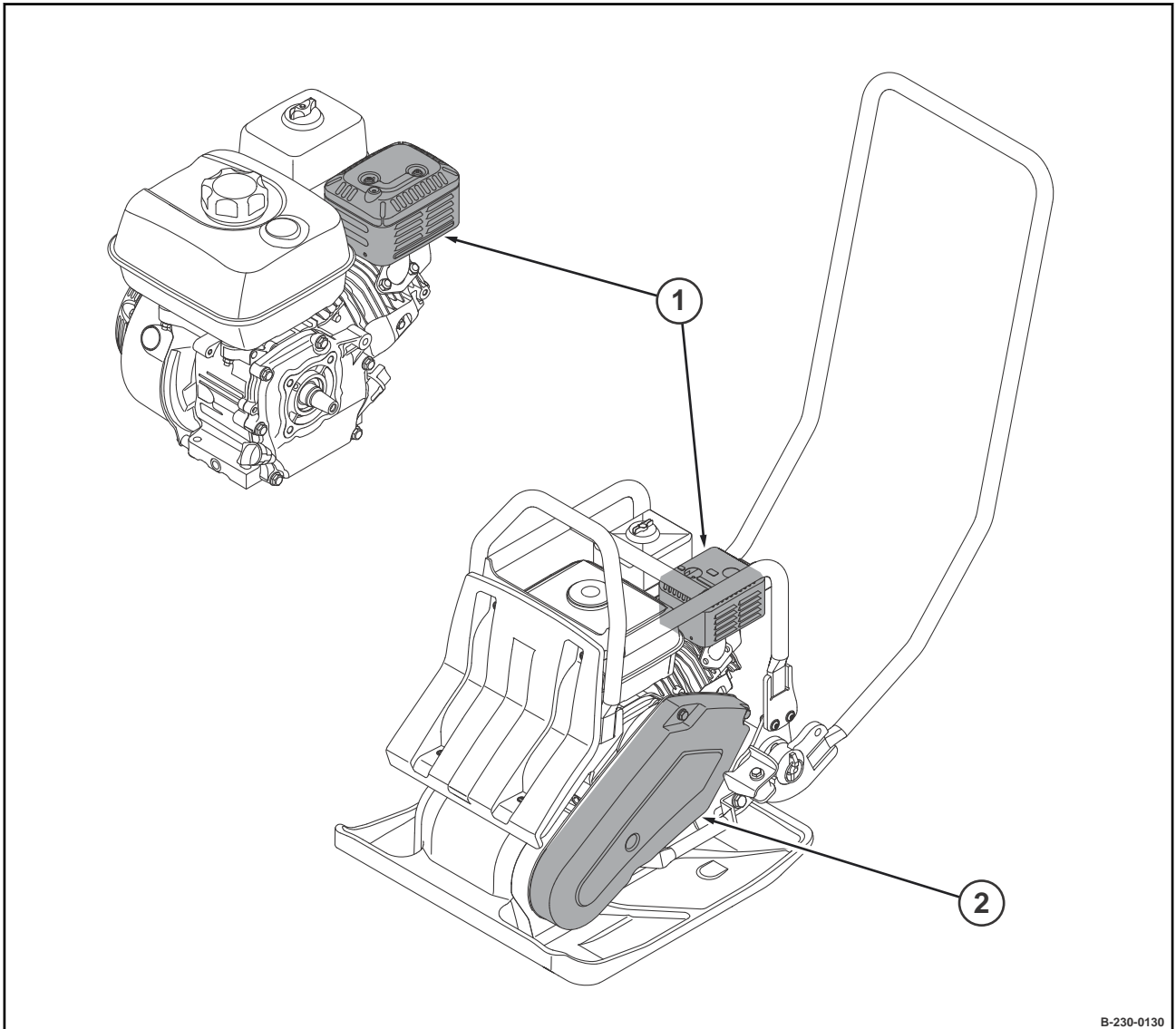

B-230-0130

Fig. 18

- 1 Heat protection cover
- 2 Belt guard

4.1 Engine

4.1.1 Overview

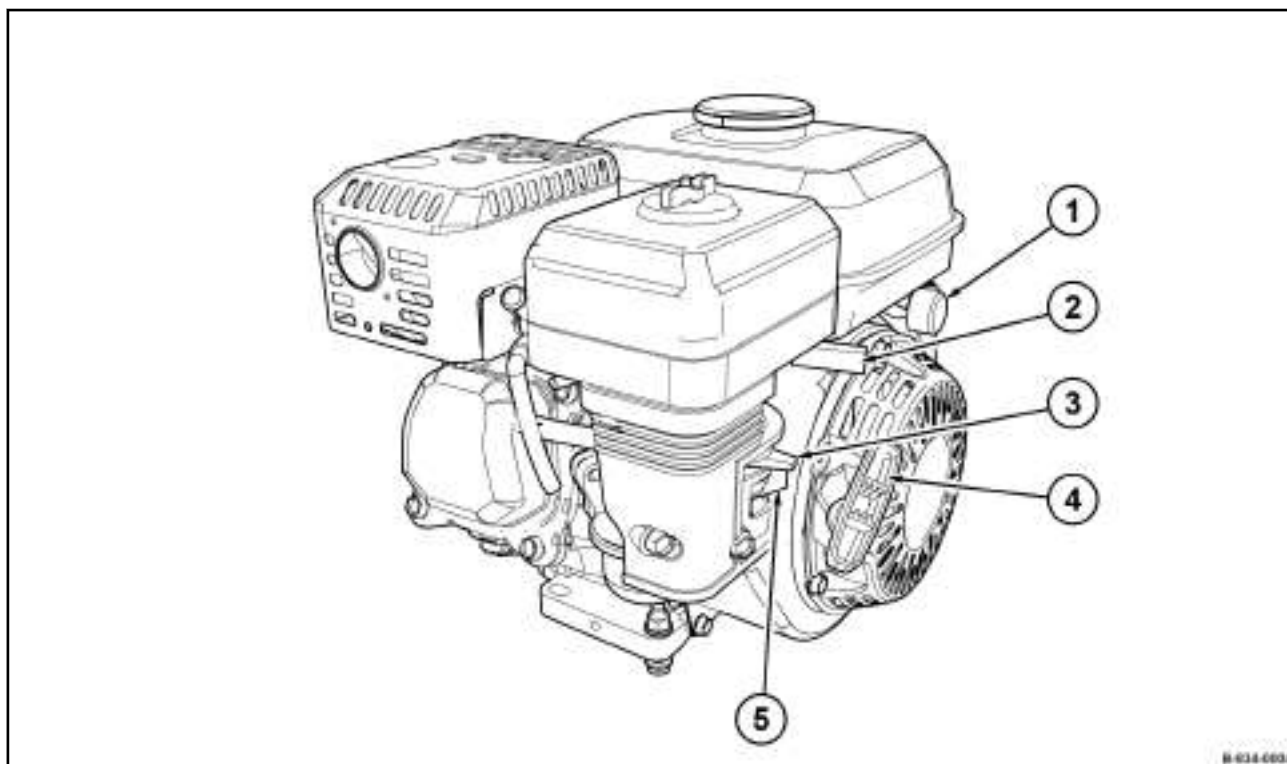

Fig. 19

- 1 Engine stop switch
- 2 Throttle lever
- 3 Choke lever
- 4 Recoil starter
- 5 Fuel valve

4.1.2 Engine stop switch

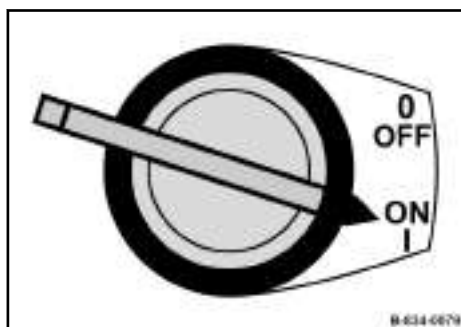

Fig. 20

Position "OFF"

Ignition off

Position "ON"

Ignition on

4.1.3 Throttle lever

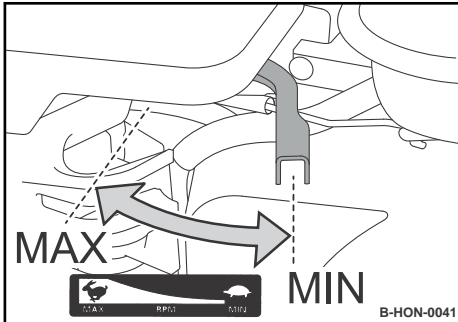

Position "MIN"	Idle speed
Position "MAX"	Maximum speed

Fig. 21

4.1.4 Choke lever

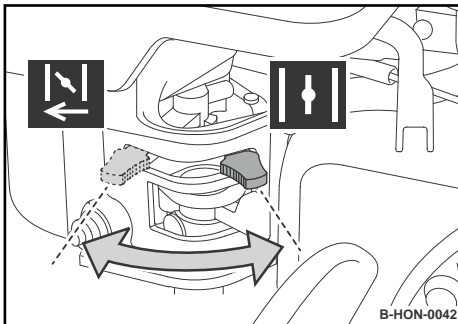

Position "Left"	Choke closed
Position "Right"	Choke open

Fig. 22

4.1.5 Recoil starter

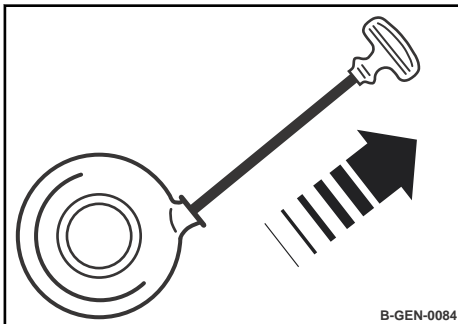
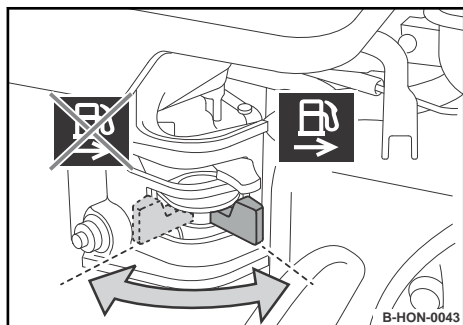

Fig. 23

4.1.6 Fuel valve



Position "Left"	Fuel valve closed
Position "Right"	Fuel valve open

Fig. 24

4.2 Water spraying system

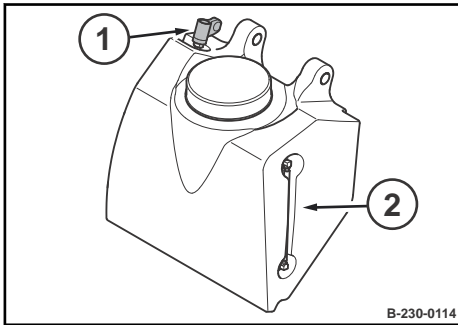

- 1 Rotary button for water spraying system
- 2 Water level gauge

Fig. 25

4.2.1 Rotary button for water sprinkling system

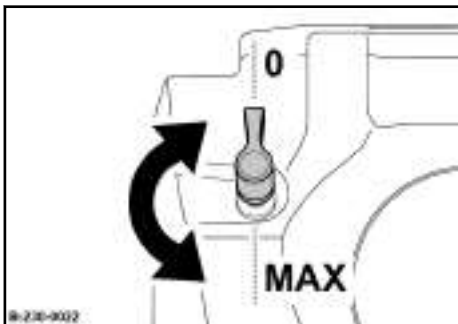

Position "0"	Water sprinkling system off
turn anticlockwise	Water sprinkling system on infinite adjustment of the sprinkling quantity up to position "MAX"

Fig. 26

4.3 Transport wheels

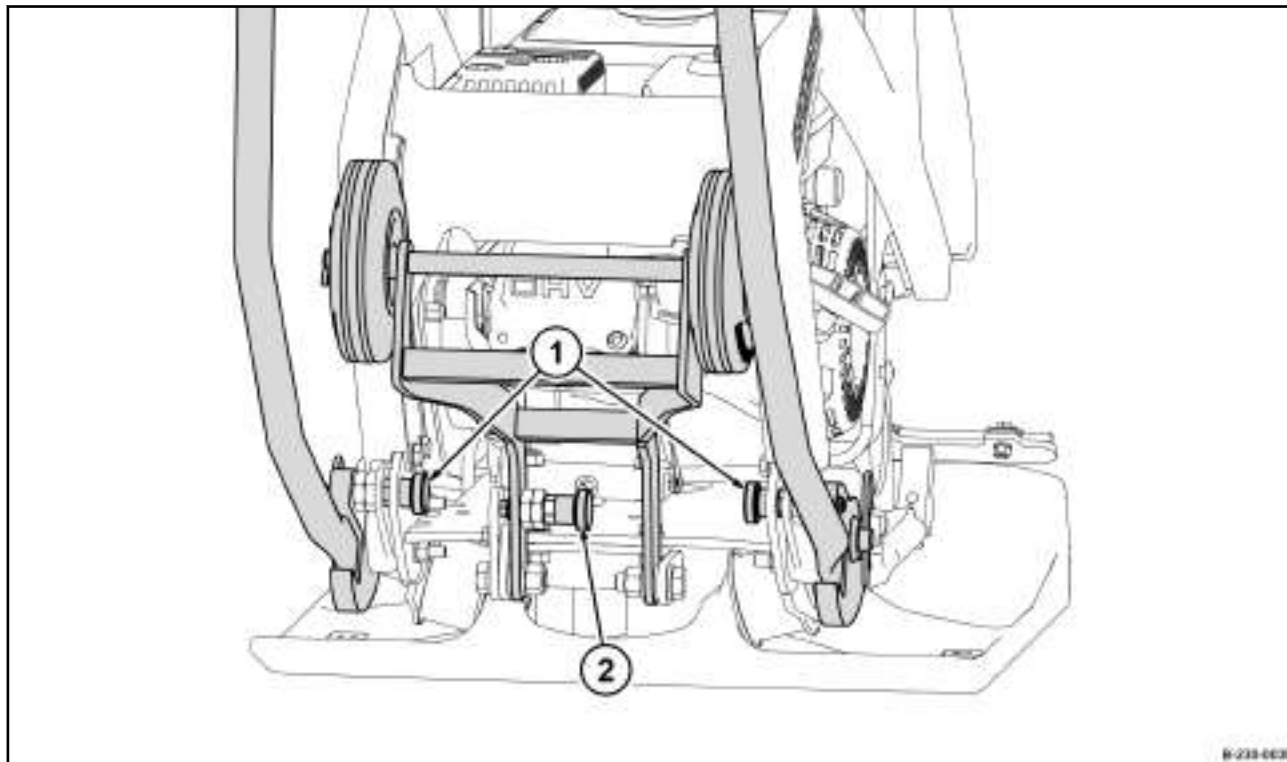

Fig. 27

- 1 Locking of guide handle
- 2 Locking of transport wheels



Optional equipment

4.3.1 Transport wheels with guide handle in middle position

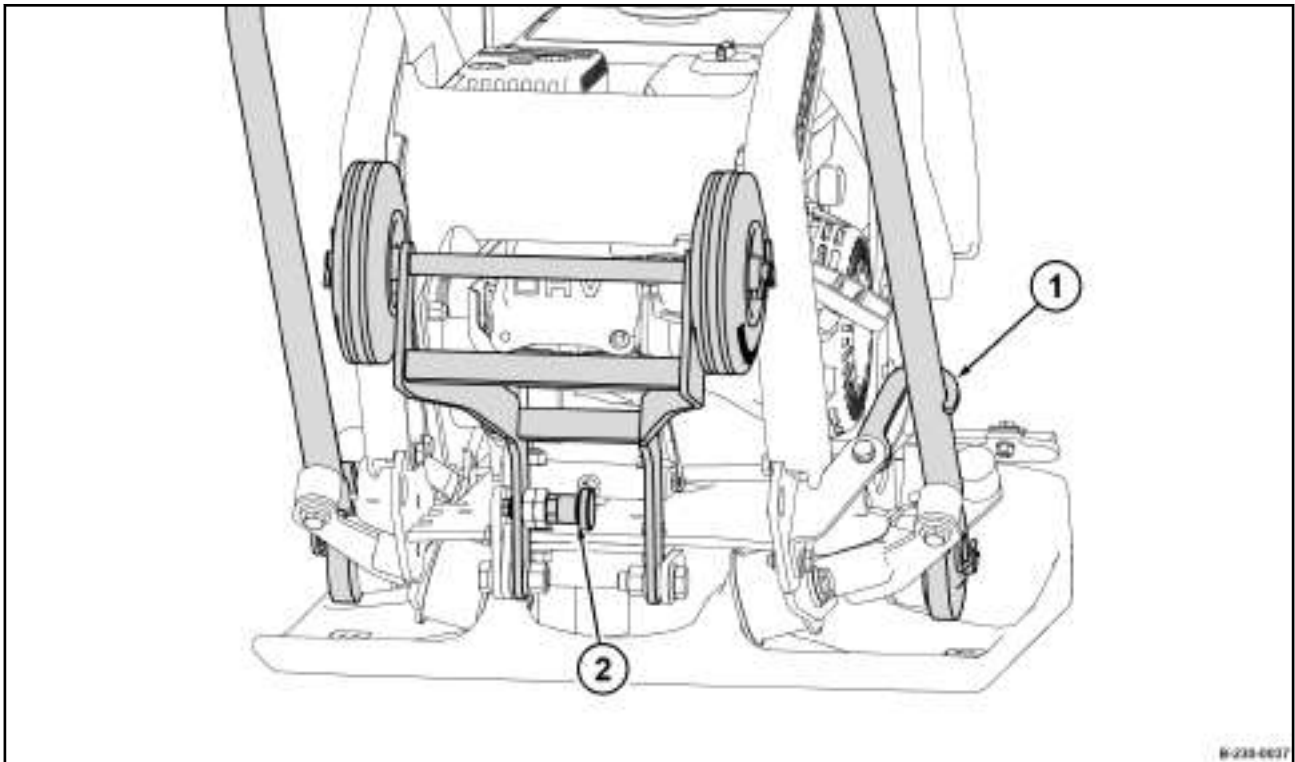

Fig. 28

- 1 Locking of guide handle
- 2 Locking of transport wheels



Optional equipment

Checks prior to start up – Notes on safety

5.1 Notes on safety

If the following tests reveal damages or other defects, the machine must not be operated, until these deficiencies have been corrected.

Do not operate the machine with defective indicators and control elements.

Safety installations must not be removed or made ineffective.

Do not change any fixed settings.



WARNING!

Health hazard caused by fuels and lubricants!

- Safety regulations and environmental protection regulations must be followed when handling fuels and lubricants ↪ *Chapter 3.4 'Handling fuels and lubricants' on page 23.*



WARNING!

Danger of injury caused by rotating parts!

- Before starting work on the machine make sure that the engine can not be started.

1. Park the machine safely ↪ *Chapter 6.5 'Parking the machine in secured condition' on page 65.*

5.2 Visual inspections and function tests

1. Check the condition of the fuel tank and fuel lines and for leaks.
2. Check the bolted connections are tight and secure.
3. Check the machine for contamination and damage.
4. Check the hydraulic oil cooler for dirt.
5. Check the starter rope for chafing.

5.3 Checking the engine oil level

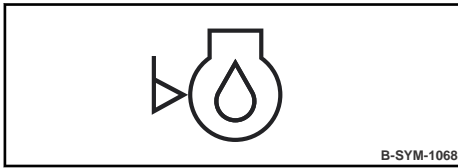

Fig. 29



NOTICE!

Danger of engine damage!

- +Use only oil of the permitted specification
↳ Chapter 8.2.1 'Engine oil' on page 75.

Protective equipment: ■ Working clothes
■ Safety shoes
■ Protective gloves

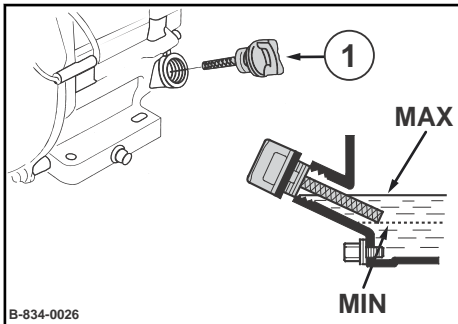

Fig. 30

1. Clean the area around the oil dipstick (1).
2. Unscrew the dipstick and wipe it clean with a lint-free, clean cloth.
3. Insert the dipstick into the oil filler socket, do not screw it in, but pull it out again to check the oil level.
⇒ The oil level must be between the "MIN" and "MAX" marks.



NOTICE!

Danger of engine damage!

- Do not fill in too much engine oil.

If the oil level is too low, top up oil to the "MAX" mark.

5. Screw the oil dipstick in.

5.4 Checking the fuel level; topping up fuel

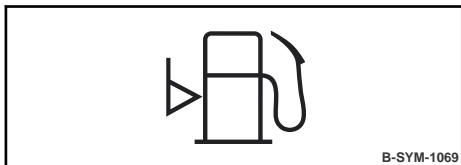

Fig. 31



DANGER!

Danger to life caused by explosive gas-air mixes!

- Do not allow gasoline to come into contact with hot components.
- Smoking and open fire is prohibited.
- Keep away from heat sources, sparks and other sources of ignition.
- Do not spill any gasoline.



NOTICE!

Danger of engine damage!

- Monitor the entire refuelling process.
- Contaminated fuel can cause malfunction or even damage of the engine. If necessary, fill in fuel through a screen filter.
- Use only fuel of the permitted specification
↪ *Chapter 8.2.2 'Fuel' on page 75.*

Protective equipment: ■ Working clothes
■ Safety shoes
■ Protective gloves

1. Park the machine safely ↪ *Chapter 6.5 'Parking the machine in secured condition' on page 65.*
2. Clean the area around the filling port.
3. Remove the cap and check the filling level visually.
4. If necessary, fill in fuel through a funnel with screen filter.
5. Close the cap.



Fig. 32

5.5 Checking the rubber buffers

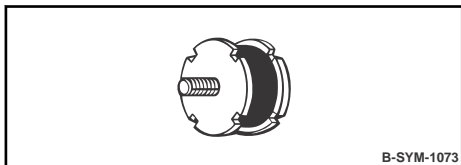

Fig. 33

Protective equipment: ■ Working clothes
■ Safety shoes
■ Protective gloves

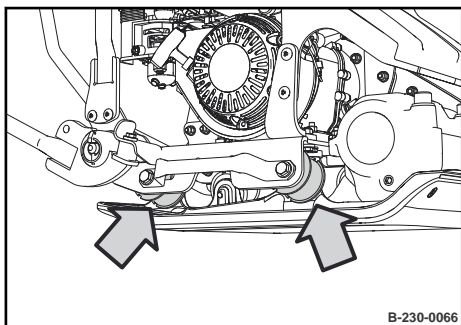

Fig. 34

1. Check the rubber buffer pairs, left and right, for tight fit, cracks and tear-offs.
 - ⇒ Have damaged rubber buffers replaced by authorised service personnel immediately.

5.6 Checking the water level, topping up



NOTICE!

Components may get damaged by frost!

- Drain all water off if there is a risk of frost.

Protective equipment: ■ Working clothes
■ Safety shoes
■ Protective gloves

1. Clean the area around the filling port.
2. Remove the cap and check the water supply in the water tank.



NOTICE!

Dirty or contaminated water can block the bore-holes!

- Fill only with clean water.

3. If necessary, fill in clean water.
4. Close the cap.

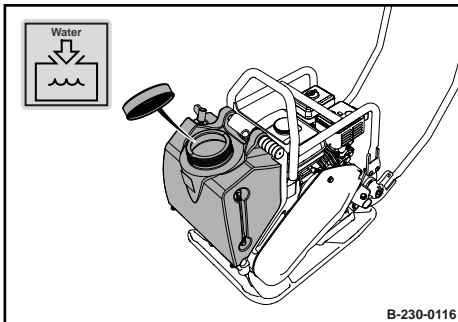

Fig. 35

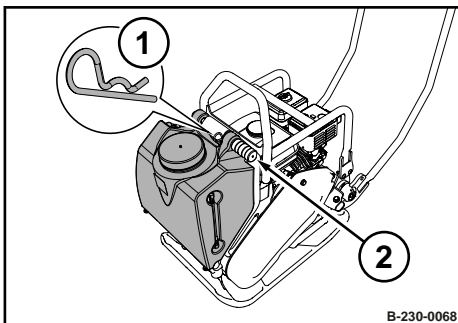

Fig. 36

Alternatively, the water tank can also be removed and transported for filling.

1. Pull out the split pin (1).
2. Pull out the bolt (2) and take off the water tank.
3. Insert the bolt through the guides on the water tank and insert the split pin to lock.
⇒ The water tank can now be carried by the bolt.

Checks prior to start up – Checking the water level, topping up

Operation – Mounting the guide handle

6.1 Mounting the guide handle

Protective equipment: ■ Working clothes
■ Safety shoes
■ Protective gloves

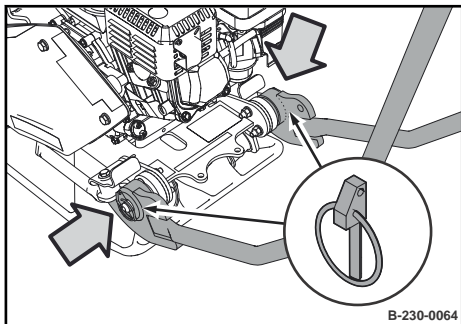

Fig. 37

1. Force the guide handle apart and plug it onto the brackets.
2. Lock and secure the guide handle on both sides with clip pins.

6.2 Starting the engine

Exhaust fumes contain toxic substances and can damage your health, cause unconsciousness or even death.



WARNING!

Danger of poisoning by exhaust gases!

- Do not inhale exhaust gases.
- Avoid operation in closed or partly closed rooms, or ensure adequate ventilation when working in trenches.

Components can be very hot during or immediately after operation.



WARNING!

Danger of burning on hot components!

- Wear your personal protective equipment (protective gloves, protective clothing).
- Avoid touching hot components.



WARNING!

Loss of hearing caused by too high noise burdens!

- Wear your personal protective equipment (ear protection).

Operate the machine only with the guide handle mounted and lowered.

Protective equipment:

- Hearing protection
- Working clothes
- Protective gloves
- Safety shoes



The engine does not start if the oil level is too low.

1. Fold down the guide handle into working position.
2. Make sure that nobody is in the danger zone.

Operation – Starting the engine

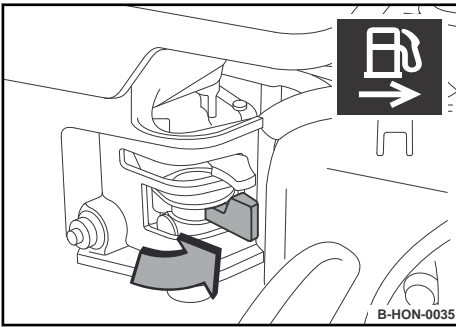

Fig. 38

3. Fully open the fuel tap.

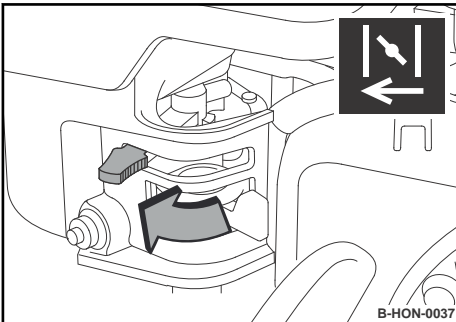



Fig. 39

4.  *Close the choke only when the engine is cold.*
If the engine is warm or the outside temperatures are high, the choke must remain open to prevent the engine from stalling.

Close the choke.

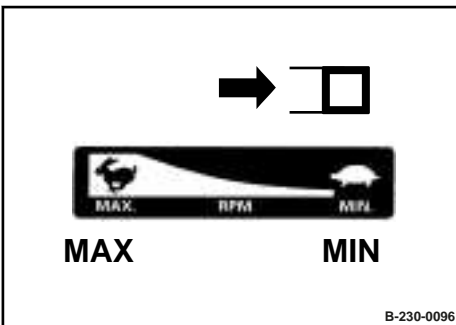

Fig. 40

5. Set the throttle lever to "MIN" position.

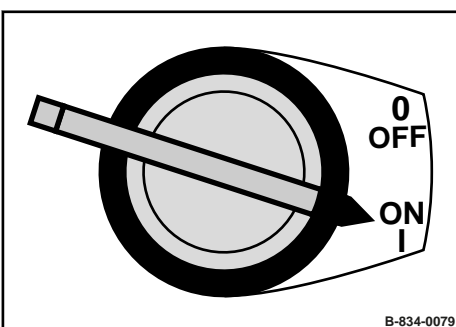

Fig. 41

6. Switch the engine stop switch to "ON" position.

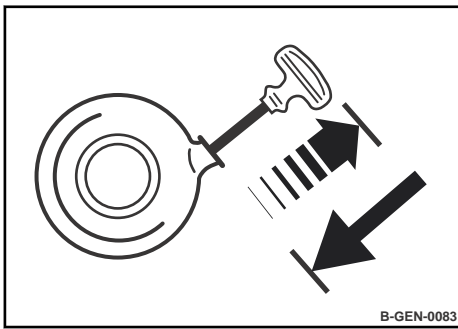

Fig. 42

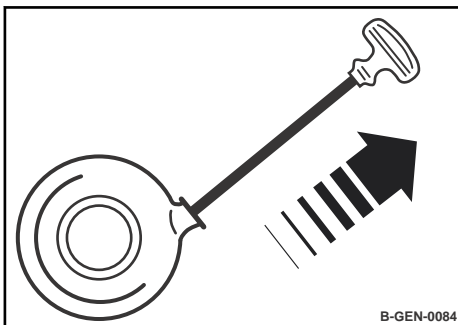

Fig. 43

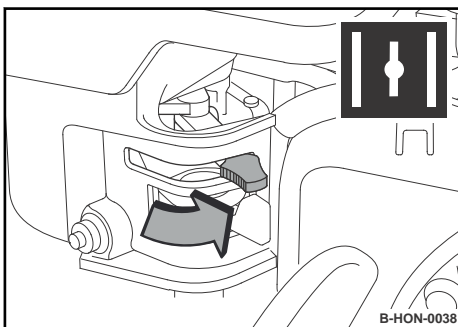

Fig. 44

7. Pull the rope by the starter handle, until resistance can be felt.
8. Guide the starter handle back to initial position.

9.



CAUTION!

Danger of injury caused by uncontrolled machine movement!

- Always hold on to a running machine.
- Always keep an eye on a running machine.



NOTICE!

The starter rope may tear off!

- Do not pull the starter rope all the way against the end stop.

Pull the starter handle quickly and with power.

10. Manually guide the starter handle back to initial position.
11. If the engine does not start during the first attempt, repeat the starting process.
12. Open the choke bit by bit when the engine is running.
13. Run the engine warm for approx. 1 to 2 minutes in idle speed.



NOTICE!

Danger of engine damage!

- Warm up engine for a short while before starting work. Do not operate the engine immediately under full load.

14. If the engine stops again after approx. 3 to 5 seconds:
 - Close the choke again.
 - Repeat the starting procedure.



If the recoil starter is frequently operated with the choke closed, the engine will draw in too much fuel and is unable to start. See Chapter 9.3 'What to do if the engine has flooded' on page 107.

6.3 Operation

Guide the machine only by the guide handle.

Guide the machine so that your hands do not hit against solid objects.

Keep feet clear of the vibrating base plate.



CAUTION!

Danger of injury caused by uncontrolled machine movement!

- Always hold on to a running machine.
- Always keep an eye on a running machine.

Components can be very hot during or immediately after operation.



WARNING!

Danger of burning on hot components!

- Wear your personal protective equipment (protective gloves, protective clothing).
- Avoid touching hot components.



WARNING!

Loss of hearing caused by too high noise burdens!

- Wear your personal protective equipment (ear protection).

- Protective equipment:
- Hearing protection
 - Working clothes
 - Protective gloves
 - Safety shoes

1. Make sure that no persons are in the danger zone.

2.



NOTICE!

The centrifugal clutch may be damaged!

- Operate the machine only with the throttle lever in “MAX” position.

Set the throttle lever to “MAX” position.

⇒ Machine vibrates forward.

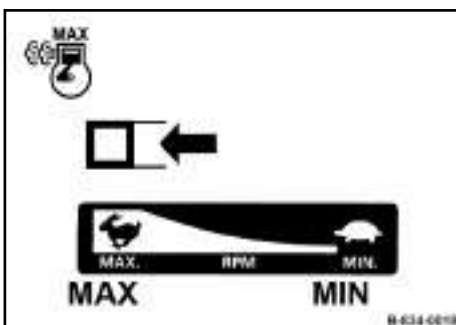

Fig. 45

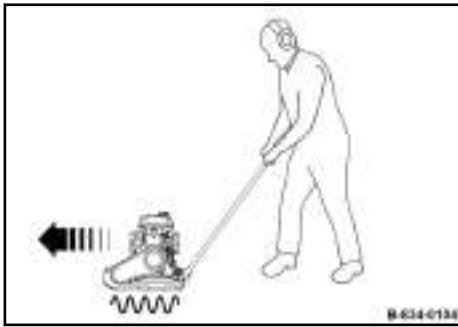

Fig. 46

3. Guide the machine by means of the guide handle.

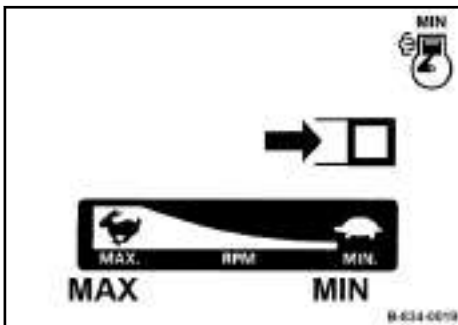

Fig. 47

4. For short work interruptions you should always return the throttle lever to "MIN" position (idle speed).
⇒ Vibration is switched off.

6.4 Switching the water sprinkling system on/off

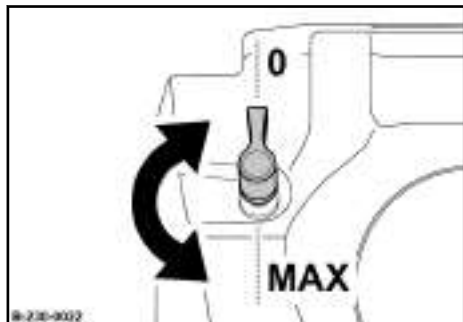

Fig. 48

1. Switch the water sprinkling system on or off with the rotary button:

Position "0"	Water sprinkling system off
turn anticlockwise	Water sprinkling system on infinite adjustment of the sprinkling quantity up to position "MAX"

6.5 Parking the machine in secured condition

Components can be very hot during or immediately after operation.



WARNING!

Danger of burning on hot components!

- Wear your personal protective equipment (protective gloves, protective clothing).
- Avoid touching hot components.

Protective equipment:

- Hearing protection
- Working clothes
- Protective gloves
- Safety shoes

1. Park the machine on level and firm ground.
2. Set the throttle lever to “MIN” position (idle speed).

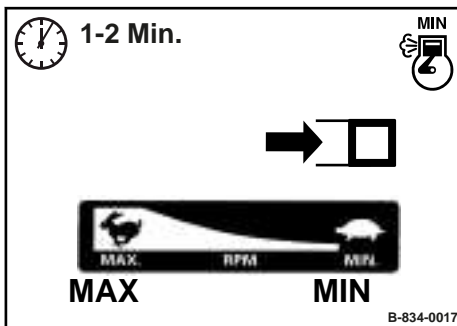

Fig. 49

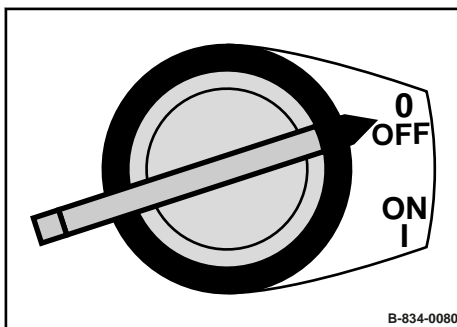

Fig. 50

3.



NOTICE!

Danger of engine damage!

- Do not shut down the engine all of a sudden from full load speed, but let it idle for about two minutes.

Switch the engine stop switch to “OFF” position.

⇒ The engine is shut down.

Operation – Parking the machine in secured condition

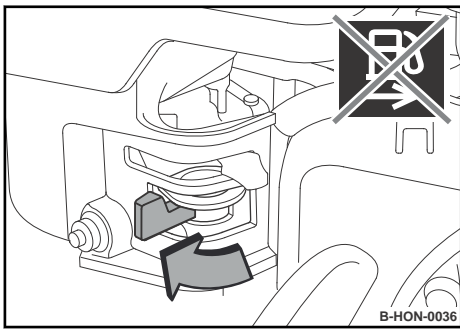

Fig. 51

4. Close the fuel valve completely.
5. Secure the machine against unauthorised use.

7.1 Loading the machine

Loads may only be attached and hoisted by an expert/qualified person.

Do not use lifting points that are damaged or impaired in any other way.

Only use lifting and lashing tackle with sufficient load bearing capacity for the weight to be loaded. Minimum load bearing capacity of lifting tackle: see operating weight ↗ *Chapter 2 'Technical data' on page 11.*

Always use appropriate lifting and lashing tackle at the lifting and lifting points.

Use lifting tackle only in the specified loading direction.

Lifting tackle must not be damaged by machine parts.

When lifting the machine, make sure the load does not move in an uncontrolled way. If necessary, hold the load steady with guide ropes.

Protective equipment:

- Working clothes
- Hard hat
- Safety shoes
- Protective gloves

1. Park the machine safely ↗ *Chapter 6.5 'Parking the machine in secured condition' on page 65.*
2. Allow the engine to cool down.
3. Fold the guide handle forwards.
4. Attach the lifting tackle to the dedicated lifting eye.
- 5.

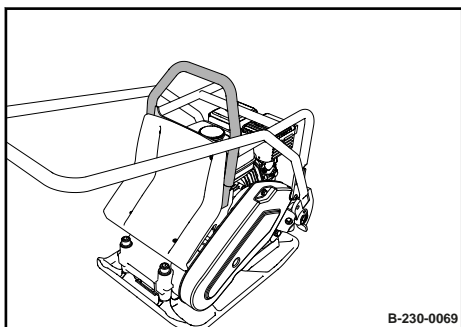

Fig. 52



DANGER!

Danger to life caused by suspended loads!

- Do not step or stand under suspended loads.

Lift the machine carefully and set down again at the intended location.

Loading/transporting the machine – Loading the machine

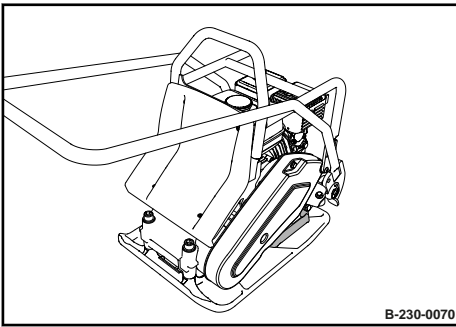

Fig. 53

6. If necessary, pull the machine by the handles or loops (1) on an even surface.

7.2 Lashing the machine to the transport vehicle

Do not use lifting points that are damaged or impaired in any other way.

Always use appropriate lifting and lashing tackle at the lifting and lashing points.

Use lifting tackle only in the specified loading direction.

Lifting tackle must not be damaged by machine parts.

Protective equipment: ■ Working clothes
■ Safety shoes
■ Protective gloves

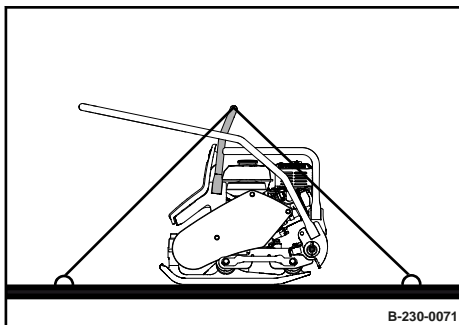

Fig. 54

1. Fasten the lashing tackle to the marked lashing point.

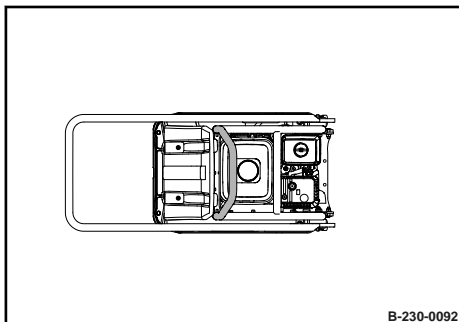

Fig. 55

2. Lash the machine securely to the transport vehicle as shown.
3. Use suitable gear to prevent the guide handle from swinging over unintentionally.

7.3 Transport wheels

1. Park the machine safely ↪ *Chapter 6.5 'Parking the machine in secured condition' on page 65.*
2. Lock the guide handle with the locking bolts (1).

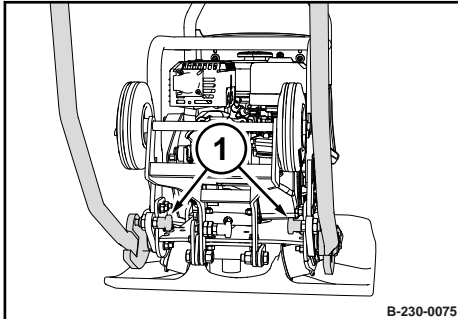

Fig. 56

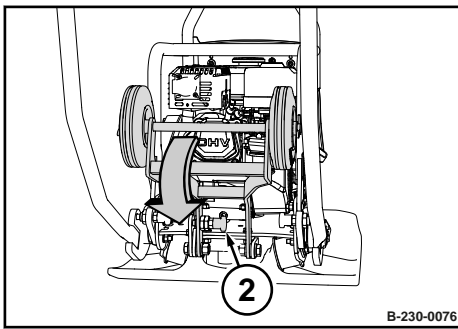

Fig. 57

3. Unlock the locking bolts (2) and fold down the transport wheels.

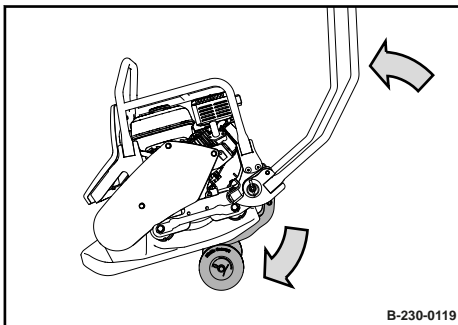

Fig. 58

4. Push the machine up by the guide handle and fold the transport wheels under the base plate.
⇒ The machine can now be moved.

Loading/transporting the machine – Transport wheels

7.3.1 Transport wheels with guide handle in middle position

1. Park the machine safely ↪ *Chapter 6.5 'Parking the machine in secured condition' on page 65.*
2. Lock the guide handle with the hook (1).

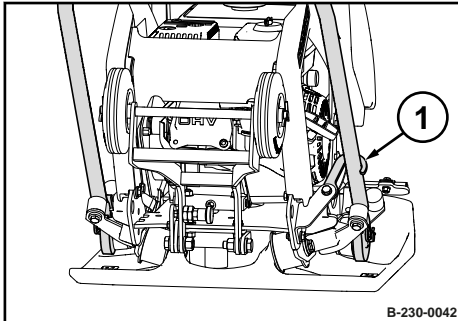

Fig. 59

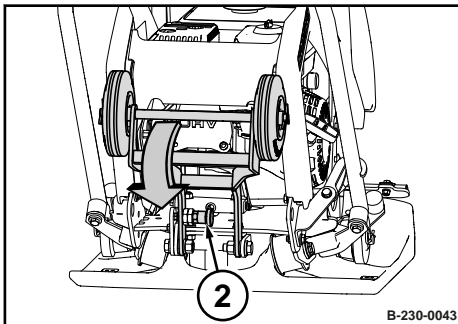

Fig. 60

3. Unlock the locking bolts (2) and fold down the transport wheels.

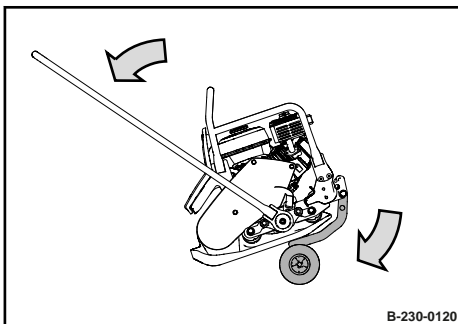

Fig. 61

4. Push the machine up by the guide handle and fold the transport wheels under the base plate.
⇒ The machine can now be moved.

8.1 Preliminary remarks and safety notes



DANGER!

Danger to life caused by an operationally unsafe machine!

- The machine must only be serviced by qualified and authorized personnel.
- Follow the safety regulations for maintenance work ↪ *Chapter 3.9 'Maintenance work' on page 32.*



WARNING!

Health hazard caused by fuels and lubricants!

- Safety regulations and environmental protection regulations must be followed when handling fuels and lubricants ↪ *Chapter 3.4 'Handling fuels and lubricants' on page 23.*

Wear your personal protective equipment.

Do not touch hot components.

Park the machine on horizontal, level, firm ground.

Perform maintenance work only with the engine shut down and the spark plug connector disconnected.

Make sure that the engine cannot be accidentally started during maintenance work.

Thoroughly clean machine and engine before starting maintenance work.

Do not leave any tools or other objects, that could cause damage, in or on the machine.

After maintenance work has been completed, dispose of fuels and lubricants, filters, sealing elements and cleaning cloths in an environmentally friendly way.

After all maintenance work is completed reinstall all guards and safety installations.

8.2 Fuels and lubricants

8.2.1 Engine oil

8.2.1.1 Oil quality

The following engine oil specifications are permitted:

- Engine oils for four-stroke engines acc. to API-classification SJ or higher

Avoid mixing of engine oils.

8.2.1.2 Oil viscosity

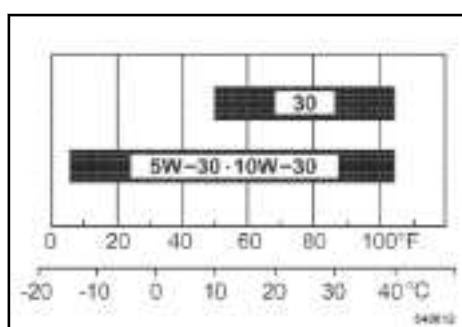

Fig. 62

Since engine oil changes its viscosity with the temperature, the ambient temperature at the operating location of the engine is of utmost importance when choosing the viscosity class (SAE-class).

The temperature data of the SAE-class always refers to fresh oils. In travel operation engine oil ages because of soot and fuel residues. This adversely affects the properties of the engine oil, especially under low ambient temperatures.

SAE 10W-30 is recommended for general use.

You may alternatively use 15W-40 (except under low temperatures).

8.2.1.3 Oil change intervals

Oil change interval: semi-annually or every 100 operating hours.

8.2.2 Fuel

8.2.2.1 Fuel quality

Use unleaded gasoline with a research octane number of 91 or higher (or octane number 86 or higher).

Use unleaded standard grade gasoline with maximum 10 percent by volume of ethanol (E10) or maximum 5 percent by volume of methanol.

Methanol must also contain co-solvents and corrosion inhibitors.

Do not use any fuel with a higher ethanol or methanol content.

The use of fuels with a higher ethanol or methanol content will cause starting and/or power problems or even cause damage in the fuel system.

8.2.2.2 Fuel stabilizer

If the machine is only occasionally used (if it is out of use for longer than four weeks), mix in the correct amount of fuel stabilizer directly after you have purchased fresh fuel.

The fuel stabilizer has a limited shelf life.

Please follow the instructions of the manufacturer concerning the correct mixing ratio and shelf life.

Mixing in fuel stabilizer does not regenerate old fuel.

8.2.3 Oil for exciter shaft housing

Use only engine oils according to the following specifications:

- API CI-4 or higher quality

Avoid mixing engine oils.



NOTICE!

Components may get damaged!

- Do not use low-ash engine oils for the exciter shaft housing.

8.3 List of fuels and lubricants

Assembly group	Fuel or lubricant		Spare parts number	Filling quantity
	Summer	Winter		Observe the level mark!
Engine oil	SAE 10W-30 Specification: ↪ <i>Chapter 8.2.1 'Engine oil' on page 75</i>			0.6 l (0.16 gal us)
	SAE 30			
Fuel	Gasoline (unleaded) Specification: ↪ <i>Chapter 8.2.2 'Fuel' on page 75</i>		DL 009 940 20	3.1 l (0.8 gal us) as required
	Fuel stabilizer Specification: ↪ <i>Chapter 8.2.2.2 'Fuel stabilizer' on page 76</i>			
Exciter shaft housing	SAE 10W-40 Specification: ↪ <i>Chapter 8.2.3 'Oil for exciter shaft housing' on page 76</i> Components may get damaged! Do not use low-ash engine oils for the exciter shaft housing.			0.3 l (0.08 gal us)
	SAE 15W-40			
	SAE 10W-30			
Water tank	Water			13.5 l (3.6 gal us)

8.4 Running-in instructions

8.4.1 General

The following maintenance work must be performed when running in new machines or overhauled engines.

8.4.2 After 25 operating hours

1. Change the engine oil ↪ *Chapter 8.7.1 'Changing the engine oil' on page 83.*
2. Check engine and machine for leaks.
3. Retighten the fastening screws on air filter, exhaust and other attachments.
4. Retighten the bolted connections on the machine.
5. Checking the V-belt ↪ *Chapter 8.9.4 'Servicing the V-belt' on page 98.*
6. Check the oil level in the vibrator housing.

8.5 Maintenance Table

No.	Maintenance works	Page
Weekly		
8.6.1	<i>Checking, cleaning the air filter</i>	80
Semi-annually		
8.7.1	<i>Changing the engine oil</i>	83
Annually		
8.8.1	<i>Replacing the spark plug</i>	84
8.8.2	<i>Checking, adjusting the valve clearance</i>	84
8.8.3	<i>Cleaning the slurry filter and fuel strainer</i>	86
8.8.4	<i>Replacing the V-belt</i>	89
8.8.5	<i>Replacing the starter rope</i>	91
8.8.6	<i>Changing the oil in the exciter housing</i>	93
8.8.7	<i>Replacing the air filter</i>	94
As required		
8.9.1	<i>Cleaning the cooling fins and the cooling air intake openings</i>	96
8.9.2	<i>Cleaning the machine</i>	97
8.9.3	<i>Cleaning the water spraying system</i>	98
8.9.4	<i>Servicing the V-belt</i>	98
8.9.5	<i>Checking, cleaning the spark plug</i>	99
8.9.6	<i>Measures prior to extended shut-down period</i>	100

8.6 Weekly

8.6.1 Checking, cleaning the air filter

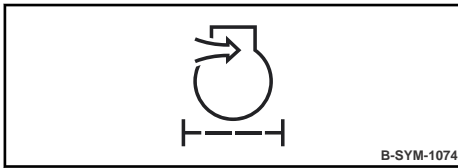

Fig. 63



NOTICE!

Danger of engine damage!

- Do not start the engine after having removed the air filter.
- If necessary, the air filter may be cleaned up to six times.
- Cleaning does not make sense if the air filter element is covered with a sooty deposit.
- Do not use gasoline or hot fluids to clean the filter element.
- After cleaning, the air filter must be inspected for damage using a torch.
- Do not continue to use a damaged air filter element. If in doubt use a new air filter.

Protective equipment:

- Working clothes
- Safety shoes
- Protective gloves
- Safety goggles

1. Park the machine safely ↪ *Chapter 6.5 'Parking the machine in secured condition' on page 65.*
2. Allow the engine to cool down.
3. Unscrew wing nut (1) and remove cover (2).
4. Clean the cover.
5. Unscrew wing nut (3) and remove filter element (4).
6. Check the rubber seal (5), replace if necessary.

Disassembling the air filter

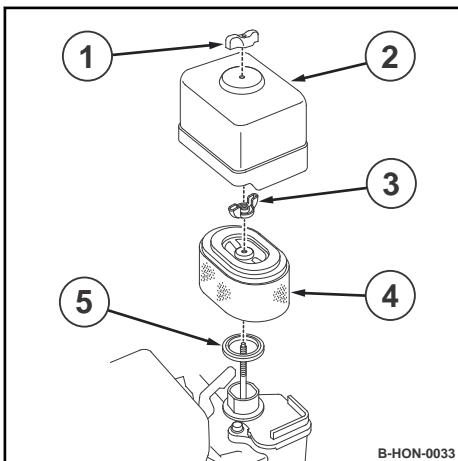

Fig. 64



The rubber seal frequently sticks to the filter element.

Checking, cleaning the air filter



Fig. 65

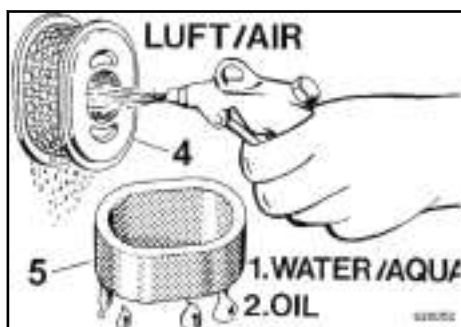

Fig. 66

7. Separate paper element and foam element.

8.



CAUTION!

Danger of eye injuries caused by particles flying around!

- Wear your personal protective equipment (safety gloves, protective working clothes, goggles).

Blow the paper element (4) out with dry compressed air (max. 2 bar (29 psi)) from inside to outside by moving the gun up and down inside the element, until it is free of dust.

9. In case of excessive dirt, replace the paper element.
10. Clean the foam element (5) in warm soapy water, rinse it and let it dry thoroughly.
11. Soak the foam element in clean engine oil and press excessive oil out.
12. Check both elements thoroughly for holes and cracks.
13. Replace if damaged.
14. Pull the foam rubber element over the paper element.

Assembling the air filter



NOTICE!

Danger of engine damage!

- Insert the filter element correctly.

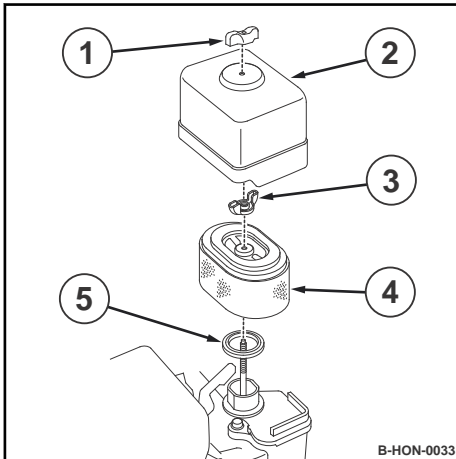

Fig. 67

15. Install the rubber seal (5).
16. Insert the filter element (4) correctly and tighten it with the wing nut (3).
17. Tighten the cover (2) with the wing nut (1).
18. Dispose of the filter element (if replaced) in an environmentally friendly way.

8.7 Semi-annually

8.7.1 Changing the engine oil

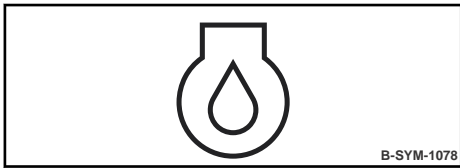

Fig. 68



NOTICE!

Danger of engine damage!

- Change the oil only with the engine at operating temperature.
- Use only oil of the permitted specification ☞ *Chapter 8.2.1 'Engine oil' on page 75.*
- Filling quantity: ☞ *Chapter 8.3 'List of fuels and lubricants' on page 77*

- Protective equipment:
- Working clothes
 - Safety shoes
 - Protective gloves

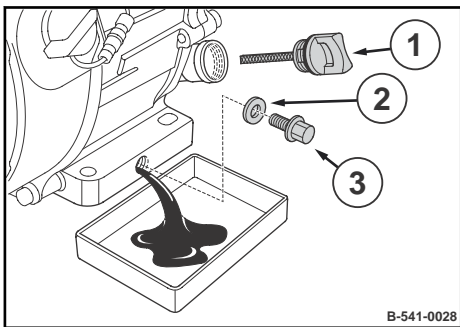

Fig. 69

1. Park the machine safely ☞ *Chapter 6.5 'Parking the machine in secured condition' on page 65.*

2.



WARNING!

Danger of burning on hot components!

- Wear your personal protective equipment (protective gloves, protective clothing).
- Avoid touching hot components.

Clean the area around oil dipstick (1) and drain plug (3).

3. Unscrew the oil dipstick.
4. Unscrew the drain plug and collect any oil running out.
5. Clean the oil drain plug and screw it back in with a new seal ring (2).
6. Fill in fresh oil up to the bottom edge of the filler bore.
7. Push the oil dipstick (1) back in.
8. Check for leaks after a short test run.
9. Check the oil level on the dipstick, correct if necessary.
10. Dispose of oil in line with environmental regulations.

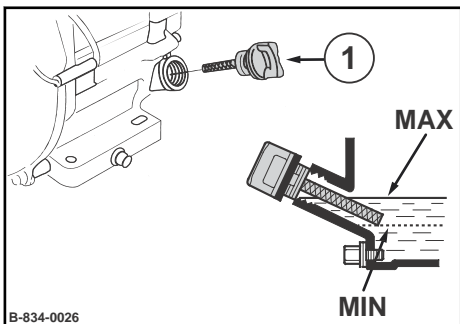

Fig. 70

8.8 Annually

8.8.1 Replacing the spark plug



NOTICE!

Danger of engine damage!

- Do not use spark plugs with incorrect heat value.

Recommended spark plugs:

NGK	BPR6ES
DENSO	W20EPR-U

Protective equipment: ■ Working clothes
■ Protective gloves

Tool: ■ 13/16 inch spark plug spanner

1. Park the machine in secured condition ↗ *Chapter 6.5 'Parking the machine in secured condition' on page 65.*
2. Allow the engine to cool down for at least 15 minutes.
3. Clean the area around the spark plug.
4. Unscrew the spark plug using a 13/16 inch spark plug spanner.
5. Check the electrode gap of the new spark plug with a feeler gauge, if necessary, adjust the gap.
⇒ **Nominal value:** 0.7 - 0.8 mm (0.028 - 0.032 in)
6. Screw in the new spark plug carefully by hand.
7. Once the sealing surface of the new spark plug is in contact, tighten for another 1/2 turn with the spark plug spanner.

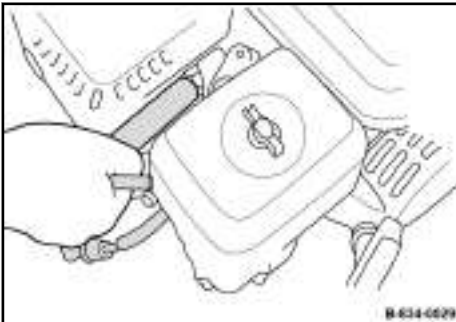

Fig. 71

8.8.2 Checking, adjusting the valve clearance



Perform this maintenance work at the latest after 250 operating hours



NOTICE!

Danger of engine damage!

We recommend to have this work carried out by trained personnel or our after sales service.

- Before checking the valve clearance let the engine cool down.

Preparations

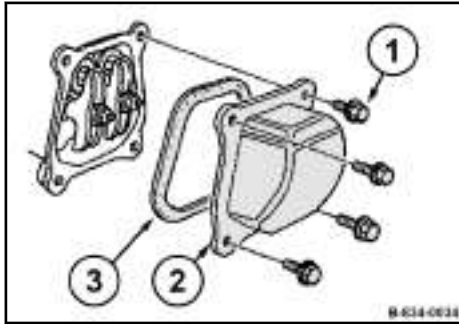

Fig. 72

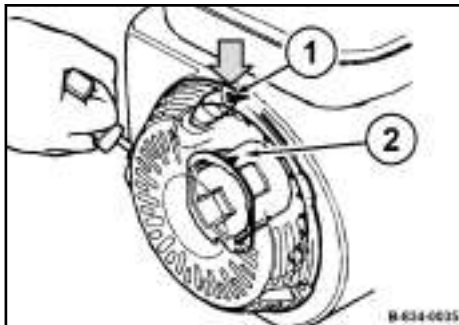

Fig. 73

Checking the valve clearance

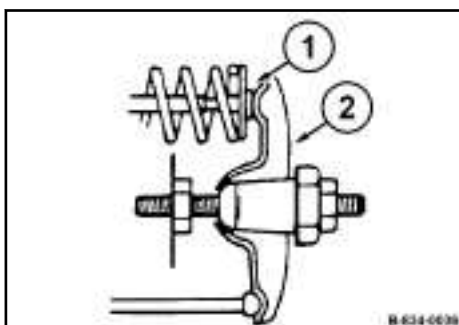

Fig. 74

Protective equipment: ■ Working clothes
■ Protective gloves

1. Park the machine in secured condition ↪ Chapter 6.5 'Parking the machine in secured condition' on page 65.
2. Let the engine cool down to 20 °C (68 °F).
3. Unscrew the fastening screws (1).
4. Remove valve cover (2) with seal (3).

5. Set the piston to the top dead centre position of the compression stroke.

For this purpose align the alignment mark (2) on the starter disc to the top bore (1).

Valve clearance:

Intake valve (IN)	0.08 mm (0.003 in)
Exhaust valve (EX)	0.10 mm (0.004 in)

1. Check the valve clearance with a feeler gauge between rocker arm (2) and valve shaft (1) on both valves, adjust if necessary.

Maintenance – Annually

Adjusting the valve clearance

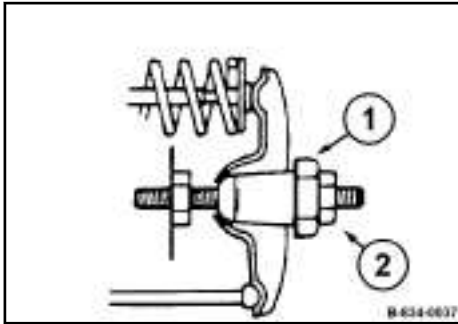

Fig. 75

1. Hold the hexagon nut (1) on the rocker arm and loosen counter nut (2).
2. Adjust the hexagon nut, until the feeler gauge can be inserted and pulled out with little resistance after retightening the counter nut.

Final work

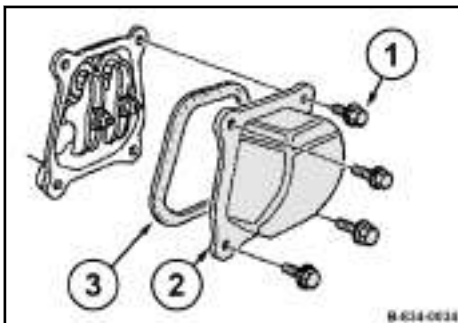

Fig. 76

1. Install the valve cover (2) with a new seal (3).
2. Tighten the fastening screws (1) evenly.
3. After a short test run, check the engine for leaks.

8.8.3 Cleaning the slurry filter and fuel strainer



DANGER!

Danger to life caused by explosive gas-air mixes!

- Do not allow gasoline to come into contact with hot components.
- Smoking and open fire is prohibited.
- Keep away from heat sources, sparks and other sources of ignition.
- Do not spill any gasoline.

Protective equipment: ■ Working clothes
■ Safety shoes
■ Protective gloves

1. Park the machine safely ↻ *Chapter 6.5 'Parking the machine in secured condition' on page 65.*
2. Allow the engine to cool down.

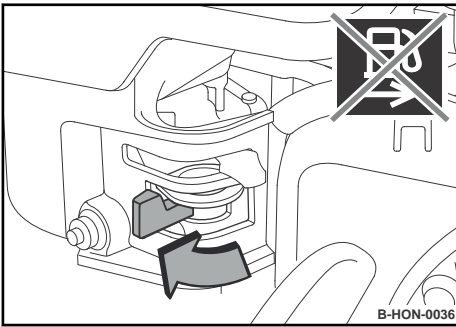

Fig. 77

3. Close the fuel valve.

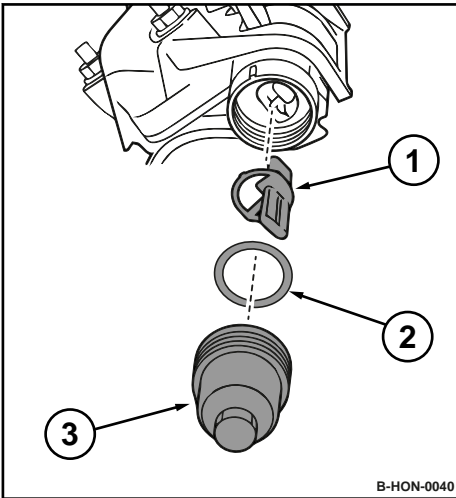

Fig. 78

4. Disassemble filter bowl (3), O-ring (2) and filter (1).
5. Clean filter bowl and filter in a non-inflammable solvent, dry them thoroughly afterwards.

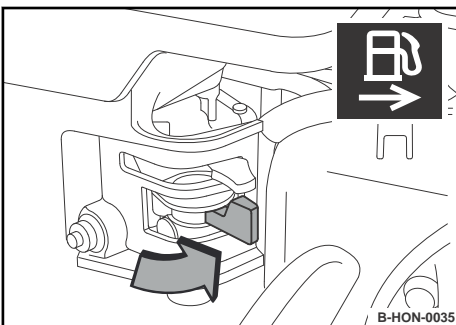

Fig. 79

6. Open the fuel valve and collect running out fuel.
7. Close the fuel valve.

Maintenance – Annually

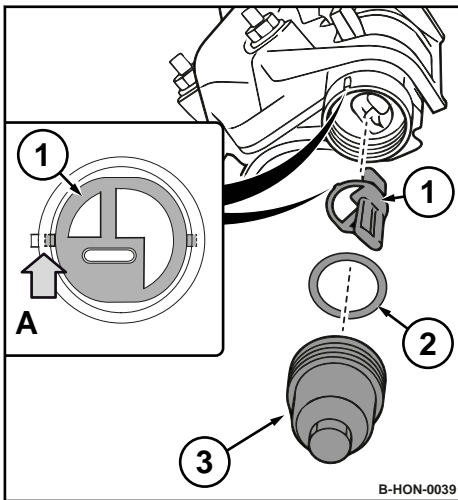

Fig. 80

A View from below: Alignment of filter during installation

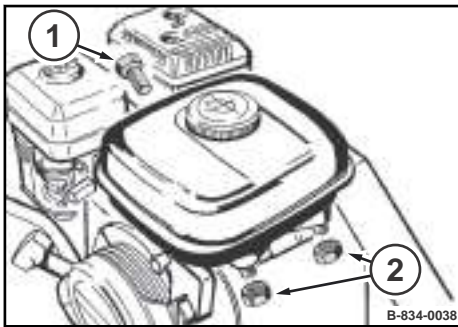

Fig. 81

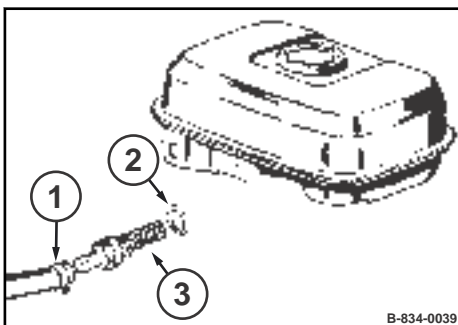

Fig. 82

8. Check the O-ring (2) for damage, replace if necessary.
9. Install the filter (1).
Observe the alignment (A) of the filter on the housing.
10. Assemble the filter bowl (3) with the O-ring.

11. Unscrew the hexagon nuts (2) and the hexagon screw (1) and take off the fuel tank.

12. Loosen the hose clamp (1) and pull off the fuel hose.
13. Unscrew the fuel strainer (3) with the seal (2).
14. Clean the fuel strainer, check the condition of the screen, replace if necessary.
15. Turn the fuel strainer tightly in with the new seal.
16. Assemble the fuel hose with the hose clamp.

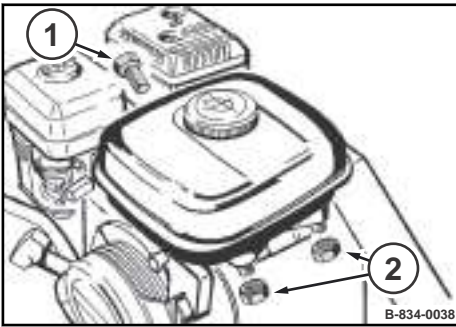

Fig. 83

17. Assemble the fuel tank with hexagon nuts (2) and hexagon screw (1).
18. Check the fuel system for leaks.
19. Dispose of fuel and replaced components in an environmentally friendly way.

8.8.4 Replacing the V-belt

Protective equipment: ■ Working clothes
 ■ Safety shoes
 ■ Protective gloves

1. Park the machine safely ↪ Chapter 6.5 'Parking the machine in secured condition' on page 65.
2. Allow the engine to cool down.
3. Loosen the fastening screws (2) and remove the V-belt guard (1).

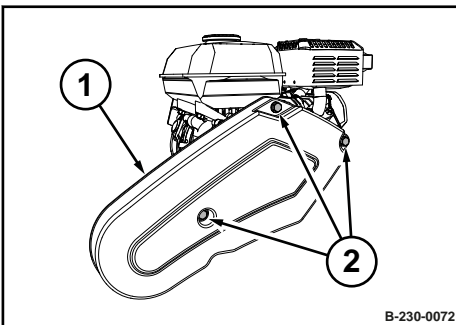

Fig. 84

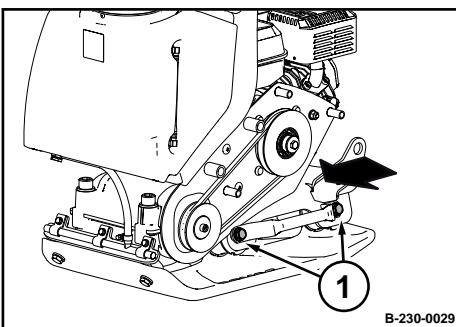

Fig. 85

4. Slightly loosen the fastening screws (1) on both sides.
5. Pull the engine carrier forward, remove and replace the V-belt.

Maintenance – Annually

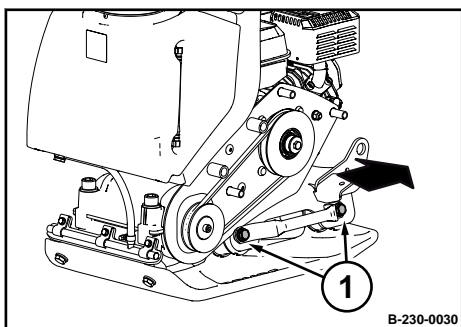

Fig. 86

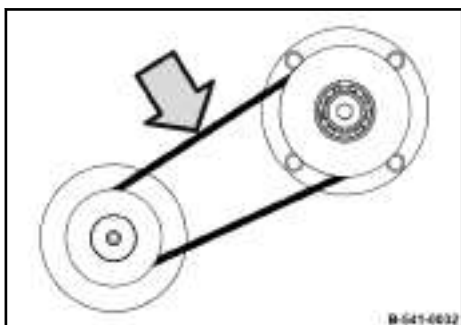

Fig. 87

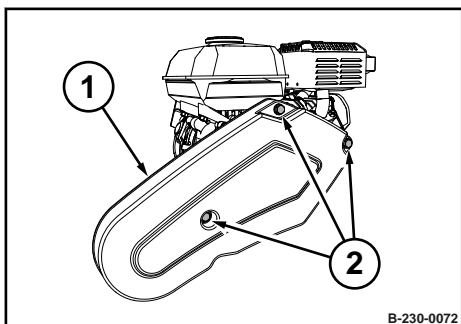

Fig. 88

6. Install the new V-belt and pull the engine carrier back.
7. Tighten the fastening screws (1) on both sides.

8. Check tension of V-belt, tighten if necessary.
⇒ **Compression measurement:** 5 - 10 mm (0.2 - 0.4 in).

9. Assemble the V-belt guard (1) with fastening screws (2).
10. Check the V-belt tension again after 25 operating hours, tighten if necessary.

8.8.4.1 Checking the frequency of the base plate

Keep feet and hands clear of the vibrating base plate.



CAUTION!

Danger of injury caused by uncontrolled machine movement!

- Always hold on to a running machine.
- Always keep an eye on a running machine.

Protective equipment: ■ Working clothes
■ Hearing protection
■ Safety shoes

Tool: ■ Sirometer

1. Park the machine on a rubber mat.
2. Start the engine ↪ *Chapter 6.2 'Starting the engine' on page 59.*
3. Run the machine at maximum speed for one minute.
4. Check the base plate's frequency with a suitable measuring instrument (e.g. Sirometer).
⇒ **Nominal value:** ↪ *Chapter 2 'Technical data' on page 11*
5. Park the machine safely ↪ *Chapter 6.5 'Parking the machine in secured condition' on page 65.*
6. If frequency incorrect:
 - Check the engine speed.
 - Check the V-belt.
 - If necessary, contact our customer service.

8.8.5 Replacing the starter rope

Protective equipment: ■ Working clothes
■ Protective gloves

1. Park the machine in secured condition ↪ *Chapter 6.5 'Parking the machine in secured condition' on page 65.*
2. Allow the engine to cool down.
3. Disassembling the recoil starter.

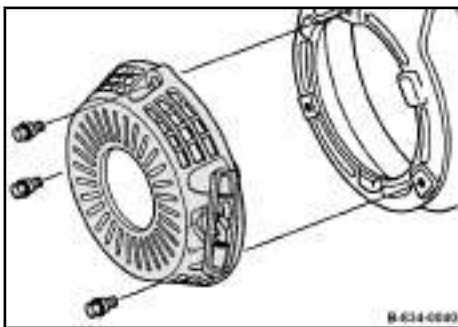

Fig. 89

Maintenance – Annually

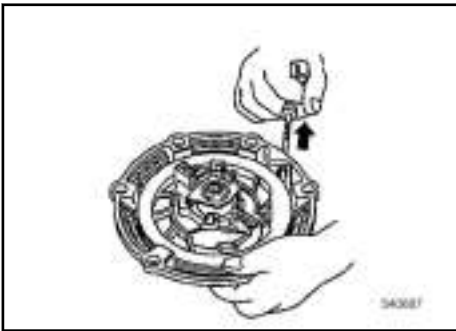

Fig. 90

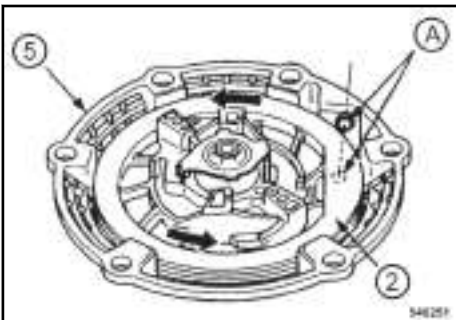

Fig. 91

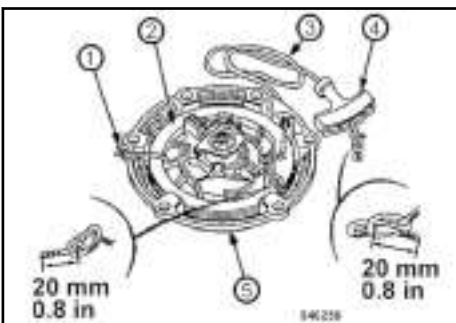

Fig. 92



Fig. 93

4. Pull the starter rope with the starter handle out completely.

5. If the starter rope has been torn or the coil has recoiled completely:

- Before assembling the rope, turn the coil (2) 5 revolutions in anti-clockwise direction and align the rope openings in coil and housing (5) to one another (A).

6. Secure the coil against winding up. For this purpose tie the coil (2) to the housing (5) with a cable strap (1).

7. Untie the knots of the starter rope at both ends and remove the old starter rope.

8. Thread in the new starter rope (3) and fix it with knots on both ends.

- 9.



CAUTION!

Danger of injury caused by the starter handle hitting against your body!

- Do not let the starter handle hit back.

Remove the fixing of the coil and run the starter handle slowly back to initial position.

10. Pull the starter handle to check the function and light movement of the recoil starter.

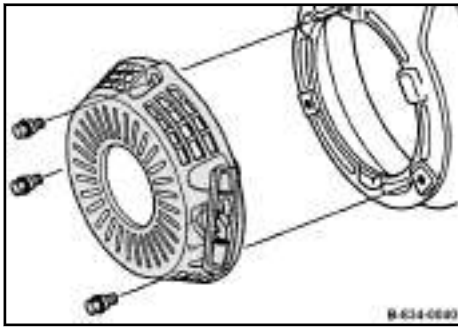

Fig. 94

11. Assemble the recoil starter.

8.8.6 Changing the oil in the exciter housing



NOTICE!

Components may get damaged!

- Use only oil of the permitted specification
 ↪ Chapter 8.3 'List of fuels and lubricants'
 on page 77.

- Protective equipment:
- Working clothes
 - Protective gloves

1. Park the machine on level ground.
2. Park the machine in secured condition ↪ Chapter 6.5 'Parking the machine in secured condition' on page 65.
3. Tilt the machine slightly towards the oil drain side and support it safely.
4. Unscrew the oil drain plug (1) and collect running out oil.

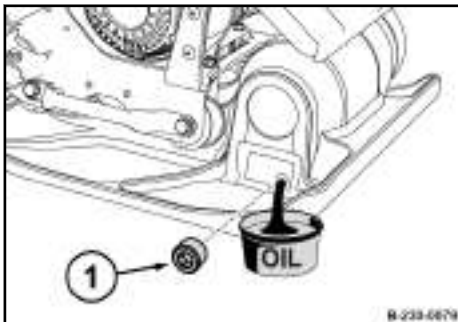

Fig. 95

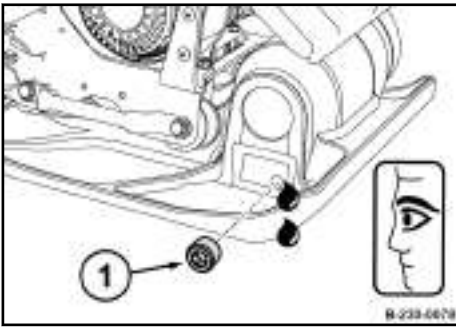

Fig. 96

5. Stand the machine upright.



NOTICE!

Components may get damaged!

Do not use low-ash engine oils for the exciter shaft housing.

6. Fill in fresh oil up to the bottom edge of the opening.
7. Screw in the oil drain plug (1).
8. Dispose of oil in an environmentally friendly way.

8.8.7 Replacing the air filter



NOTICE!

Danger of engine damage!

- Do not start the engine after having removed the air filter.

Protective equipment: ■ Working clothes
■ Safety shoes
■ Protective gloves

1. Park the machine safely ↪ Chapter 6.5 'Parking the machine in secured condition' on page 65.
2. Allow the engine to cool down.
3. Unscrew wing nut (1) and remove cover (2).
4. Clean the cover.
5. Unscrew wing nut (3) and remove filter element (4).
6. Check the rubber seal (5), replace if necessary.

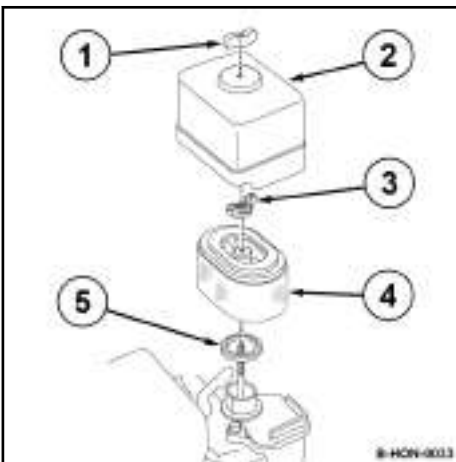

Fig. 97



The rubber seal frequently sticks to the filter element.



Fig. 98

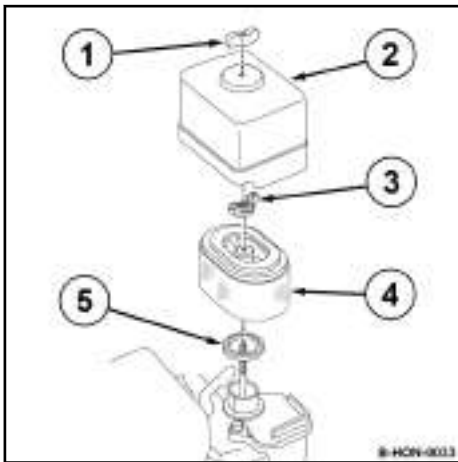

Fig. 99

7. Replace the filter element consisting of paper and foam insert.



NOTICE!

Danger of engine damage!

- Insert the filter element correctly.

8. Install the rubber seal (5).
9. Insert the filter element (4) correctly and tighten it with the wing nut (3).
10. Tighten the cover (2) with the wing nut (1).
11. Dispose of the old filter element in an environmentally friendly way.

8.9 As required

8.9.1 Cleaning the cooling fins and the cooling air intake openings



How dirty the cooling fins and cooling air intake openings are depends very much on the daily operating conditions; clean daily if necessary.



NOTICE!

Danger of engine damage caused by reduced cooling!

- For this reason you should always seal any oil or fuel leaks in the vicinity of the cooling fan or the coolers and clean the cooling fins after.

Protective equipment: ■ Working clothes
■ Protective gloves
■ Safety goggles

1. Park the machine safely ↪ *Chapter 6.5 'Parking the machine in secured condition' on page 65.*
2. Allow the engine to cool down.
3. Remove dried dirt with a suitable brush from all cooling fins and cooling air intake openings.

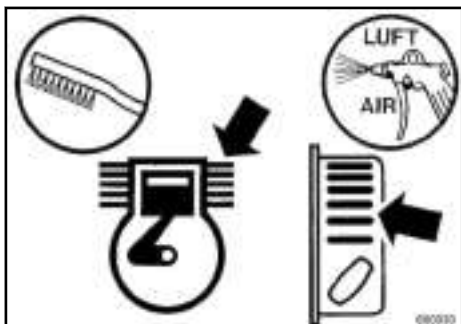

Fig. 100



CAUTION!

Danger of eye injuries caused by particles flying around!

- Wear your personal protective equipment (safety gloves, protective working clothes, goggles).

Blow out the cooling fins and cooling air intake openings with compressed air.

Cleaning with cold cleansing agent

If the engine is oily, use a cold cleansing agent for cleaning.



NOTICE!

Electric components can be damaged by water entering into the system!

- Do not direct the water jet directly into the air filter, carburettor, recoil starter, air intake or engine stop switch.

1.



CAUTION!

Danger of eye injuries caused by particles flying around!

- Wear your personal protective equipment (safety gloves, protective working clothes, goggles).

Spray the engine with a suitable, non-inflammable cleansing agent, let it soak in for a while, clean it off with water and blow out with compressed air.

2. Warm up the engine for a while to avoid corrosion.

3. Look for the cause of oily contamination and have any leaks sealed by our customer service.

8.9.2 Cleaning the machine



NOTICE!

Danger of engine damage caused by reduced cooling!

- Immediately remove any oil or fuel leaks near fuel tank, cylinders or cooling air intake.

1. Park the machine safely ↪ *Chapter 6.5 'Parking the machine in secured condition' on page 65.*

2. Allow the engine to cool down for at least 30 minutes.



NOTICE!

Electric components can be damaged by water entering into the system!

- Do not direct the water jet directly into the air filter, carburettor, recoil starter, air intake or engine stop switch.

3. Clean the machine with a water jet.

4. Warm up the engine for a while to avoid corrosion.

8.9.3 Cleaning the water spraying system

- Protective equipment:
- Working clothes
 - Safety shoes
 - Protective gloves

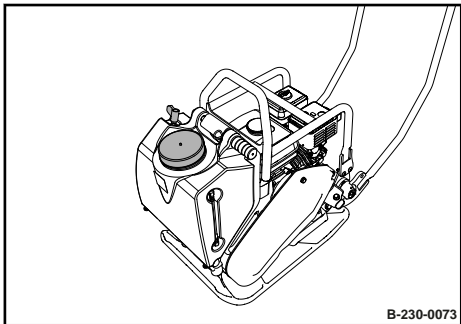

Fig. 101

1. Remove the cap (2).
2. Open the rotary button (1) completely and let all water run out.



Alternatively you may also remove the water tank for cleaning.

3. Flush the water tank with a strong water jet, until all dirt has run out.
4. Fill the water tank with clean water and close the cap.

8.9.4 Servicing the V-belt

- Protective equipment:
- Working clothes
 - Safety shoes
 - Protective gloves

1. Park the machine safely  Chapter 6.5 'Parking the machine in secured condition' on page 65.
2. Allow the engine to cool down.
3. Loosen the fastening screws (2) and remove the V-belt guard (1).

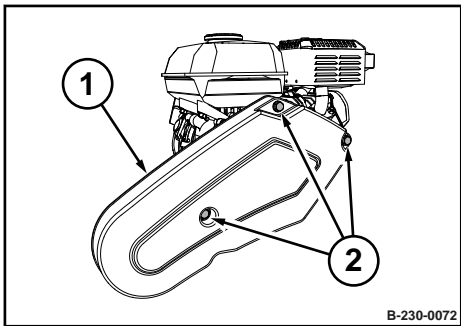

Fig. 102

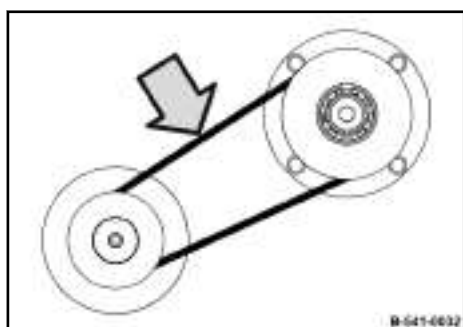

Fig. 103

1. Check condition and tension of the V-belt, tighten if necessary.
⇒ **Compression measurement:** 5 - 10 mm (0.2 - 0.4 in).
2. If necessary, tighten the V-belt; if damaged, replace the V-belt ↪ *Chapter 8.8.4 'Replacing the V-belt' on page 89.*

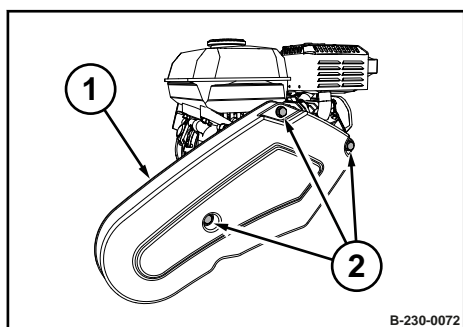

Fig. 104

3. Assemble the V-belt guard (1) with fastening screws (2).

8.9.5 Checking, cleaning the spark plug



NOTICE!

Danger of engine damage!

- Do not use spark plugs with incorrect heat value.

Protective equipment: ■ Working clothes
■ Protective gloves

Tool: ■ 13/16 inch spark plug spanner

1. Park the machine in secured condition ↪ *Chapter 6.5 'Parking the machine in secured condition' on page 65.*
2. Allow the engine to cool down for at least 15 minutes.
3. Clean the area around the spark plug.
4. Unscrew the spark plug using a 13/16 inch spark plug spanner.

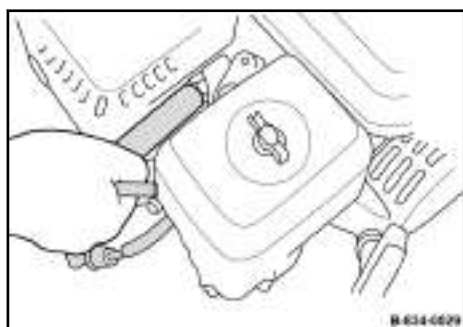

Fig. 105

Maintenance – As required

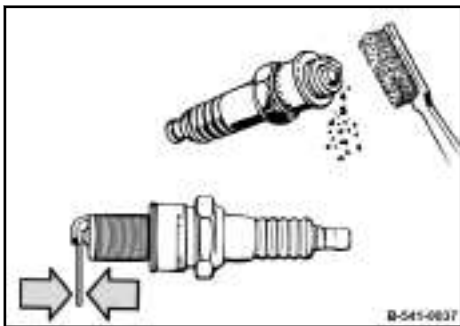

Fig. 106

5. Check the condition of the spark plug, clean if necessary.
6. In case of excessive combustion residues or burned off electrodes, replace the spark plug ↪ *Chapter 8.8.1 'Replacing the spark plug' on page 84.*
7. Check the electrode gap of the spark plug with a feeler gauge, if necessary, adjust the gap.
⇒ **Nominal value:** 0.7 - 0.8 mm (0.028 - 0.032 in)
8. Carefully screw in the spark plug by hand.
9. Once the sealing surface of the used spark plug is in contact, tighten for another 1/8 to 1/4 turn with the spark plug spanner.



NOTICE!

Danger of engine damage caused by a loose spark plug!

- Always screw the spark plug in correctly.

8.9.6 Measures prior to extended shut-down period

8.9.6.1 Measures before shutting down



DANGER!

Danger to life caused by explosive gas-air mixes!

- Do not allow gasoline to come into contact with hot components.
- Smoking and open fire is prohibited.
- Keep away from heat sources, sparks and other sources of ignition.
- Do not spill any gasoline.

If the machine is shut down for a longer period of time, e.g. winter season, the following work must be carried out.

Depending on weather influences these conservation measures will protect the machine for approx. 6 to 12 months.

1. Park the machine safely ↪ *Chapter 6.5 'Parking the machine in secured condition' on page 65.*
2. Allow the engine to cool down for at least 30 minutes.
3. Clean the machine thoroughly.
4. Change the engine oil ↪ *Chapter 8.7.1 'Changing the engine oil' on page 83.*
5. Use fuel stabilizer or empty the fuel tank completely.

Using fuel stabilizer

1. Mix fresh fuel with fuel stabilizer (follow the instructions of the manufacturer).
2. Empty the fuel tank and fill it with the prepared fuel mix.
3. Start the engine and run the machine for approx. 10 minutes in the open.
4. Park the machine in secured condition.

Emptying the fuel tank

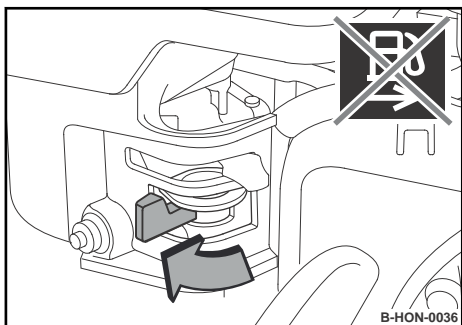

Fig. 107

1. Close the fuel valve.

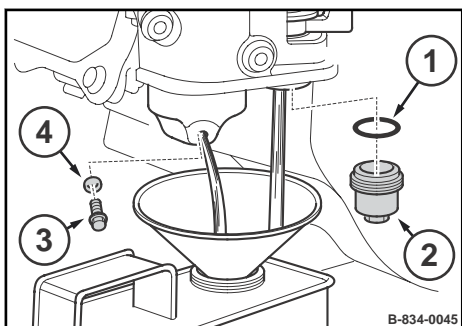

Fig. 108

2. Disassemble the drain plug (3) and the seal (4) from the carburettor and collect leaking fuel.
3. Disassemble the filter bowl (2) and the O-ring (1).
4. Open the fuel valve and collect running out fuel.
5. Close the fuel valve.
6. Install the drain plug with the seal on the carburettor.
7. Assemble the filter bowl with the O-ring.
8. Dispose of fuel in line with environmental regulations.

Protecting the cylinder

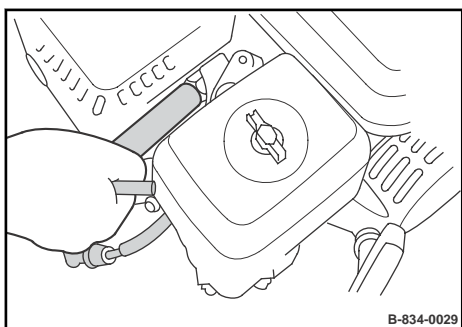

Fig. 109

Tool: ■ 13/16 inch spark plug spanner

1. Unscrew the spark plug using a 13/16 inch spark plug spanner.
2. Fill in several drops of fresh engine oil through the ignition plug opening.

Maintenance – As required

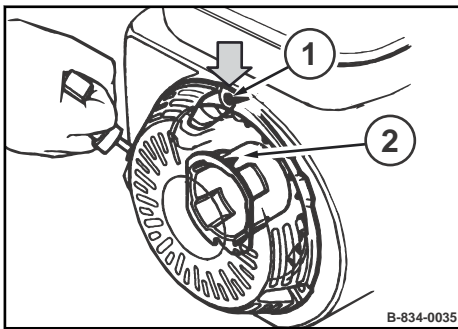

Fig. 110

Parking the machine

3. Crank the engine several times with the recoil starter to distribute the oil in the cylinder.
4. Screw the spark plug back in.
5. Slowly pull the starter rope until resistance can be felt and the alignment mark (2) on the starter disc is in line with the upper bore (1).
 - ⇒ Valves are closed so that no moisture can enter into the cylinder.
6. Slowly guide the starter rope back.

1. After shutting down store the machine under cover in a dry and well ventilated room.
2. Repair damaged paint; preserve bare areas thoroughly with anti-corrosive agent.
3. Cover the engine to protect it against dust and moisture.
4. A machine with conserved engine must be clearly marked by attaching an information sign.

8.9.6.2 Measures before restarting



DANGER!

Danger to life caused by explosive gas-air mixes!

- Do not allow gasoline to come into contact with hot components.
- Smoking and open fire is prohibited.
- Keep away from heat sources, sparks and other sources of ignition.
- Do not spill any gasoline.

1. Check the oil levels.
2. Check hoses and lines for cracks and leaks.
3. If the fuel was drained off before shutting down, you must now fill in fuel.
4. Clean the machine thoroughly.
5. Start the engine and run it for 15 to 30 minutes with idle speed.

9.1 Preliminary remarks

Malfunctions are frequently caused by incorrect operation of the machine or insufficient maintenance. Whenever a fault occurs you should therefore thoroughly read these instructions on correct operation and maintenance.

If you cannot locate the cause of a fault or rectify it yourself by following the trouble shooting chart, you should contact our customer service department.

9.2 Engine malfunctions

Fault	Possible cause	Remedy
Engine does not start	Fuel tank empty	Check, refill if necessary
	Fuel valve closed	Open the fuel valve
	Fuel system clogged	Cleaning the fuel strainer
		Check the fuel strainer in the carburettor Have it checked by qualified expert personnel
	Engine stop switch in position "OFF"	Engine stop switch in position "ON"
	Engine oil level too low	Check the engine oil level, top up if necessary
	No ignition spark	Clean the spark plug, replace if necessary
	Engine stop switch defective	Have it checked by qualified expert personnel
	No fuel in carburettor	Check the fuel supply
Have it checked by qualified expert personnel		
Engine does not crank when operating the recoil starter	Recoil starter defective	Replace the recoil starter
	Spring broken	Replace the recoil starter
Starter rope of recoil starter does not return to initial position	Recoil starter dirty	Clean the recoil starter
	Insufficient pretension of the spring	Check the pretension of the spring, adjust if necessary
	Spring broken	Replace the recoil starter
Low engine power	Air filter clogged	Clean the air filter, replace if necessary
	Throttle cable defective	Have it checked by qualified expert personnel
	Engine defective	Have it checked by qualified expert personnel
	Carburettor defective	Have it checked by qualified expert personnel
Engine overheats	Lack of cooling air	Clean the air filter, replace if necessary Cleaning the cooling fins and the cooling air intake openings
Engine stops	Fuel system clogged	Cleaning the fuel strainer
		Check the fuel strainer in the carburettor Have it checked by qualified expert personnel
	Fuel tank empty	Check, refill if necessary

Troubleshooting – Engine malfunctions

Fault	Possible cause	Remedy
	Poor fuel quality	Check the fuel quality, if necessary change the fuel
	Engine oil level too low	Check the engine oil level, top up if necessary
Engine runs with high speed, but no vibration	Centrifugal clutch defective	Have it checked by qualified expert personnel
	V-belt torn	Replacing the V-belt

9.3 What to do if the engine has flooded



DANGER!

Danger to life caused by explosive gas-air mixes!

- Do not allow gasoline to come into contact with hot components.
- Smoking and open fire is prohibited.
- Keep away from heat sources, sparks and other sources of ignition.
- Do not spill any gasoline.

Protective equipment: ■ Working clothes
■ Safety shoes
■ Protective gloves
■ Safety goggles

Tool: ■ 13/16 inch spark plug spanner

1. Allow the engine to cool down.
2. Close the fuel valve.

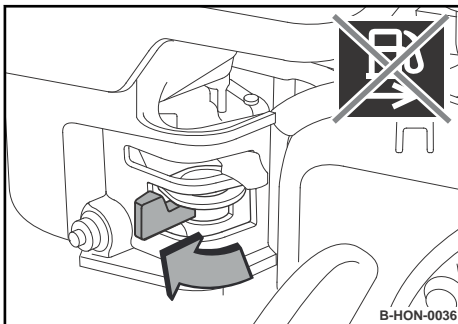

Fig. 111

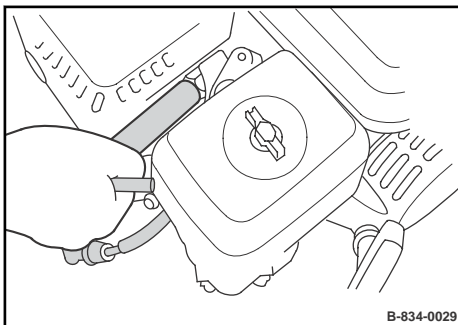

Fig. 112

3. Pull off the spark plug socket.
4. Unscrew the spark plug using a 13/16 inch spark plug spanner.
5. Have a cloth ready to soak up the fuel.

Troubleshooting – What to do if the engine has flooded

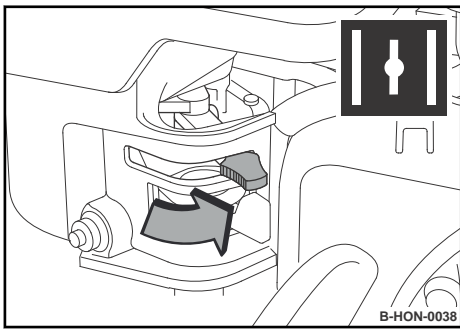

Fig. 113

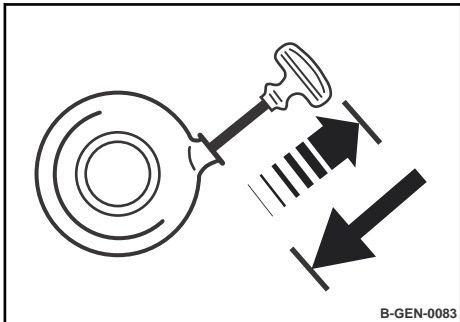

Fig. 114

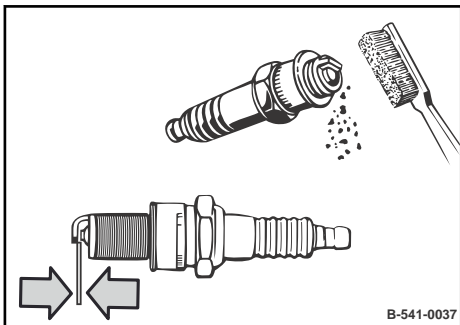

Fig. 115

6. Open the choke.

7.



CAUTION!

Danger of eye injuries caused by particles flying around!

- Wear your personal protective equipment (safety gloves, protective working clothes, goggles).

Crank the engine several times with the recoil starter to remove excessive fuel from the combustion chamber.

8. Dry the spark plug with a clean cloth or blow it dry with compressed air.
9. If necessary, clean the spark plug with a wire brush.
10. In case of excessive combustion residues or burned off electrodes, replace the spark plug.
11. Check the electrode gap of the spark plug with a feeler gauge, if necessary, adjust the gap.
 - ⇒ **Nominal value:** 0.7 - 0.8 mm (0.028 - 0.032 in)
12. Screw the used spark plug carefully in by hand and once the sealing surface of the used spark plug is in contact, tighten it for another 1/8 to 1/4 turn with the spark plug spanner.
13. Once the sealing surface of the new spark plug is in contact, tighten for another 1/2 turn with the spark plug spanner.



NOTICE!

Danger of engine damage caused by a loose spark plug!

- Always screw the spark plug in correctly.

14. Plug the spark plug socket back on.
15. Start the engine ↪ *Chapter 6.2 'Starting the engine' on page 59.*
16. Dispose of the cloth soaked with the leaked fuel in an environmentally friendly way.

Disposal – Final shut-down of machine

10.1 Final shut-down of machine

After the machine has reached the end of its service life, the individual components of the machine must be disposed of properly.

Observe national regulations!

Carry out the following work and have the machine dismantled by a state-approved recycling company.



DANGER!

Danger to life caused by explosive gas-air mixes!

- Do not allow gasoline to come into contact with hot components.
- Smoking and open fire is prohibited.
- Keep gasoline away from heat sources, sparks and other sources of ignition.
- Do not spill any gasoline.
- Components that previously contained gasoline must not be cut with a cutting torch.



WARNING!

Health hazard caused by fuels and lubricants!

- Safety regulations and environmental protection regulations must be followed when handling fuels and lubricants ↪ *Chapter 3.4 'Handling fuels and lubricants' on page 23.*

Protective equipment: ■ Working clothes
■ Safety shoes
■ Protective gloves
■ Safety goggles

1. Empty the fuel tank.
2. Drain engine oil from engine and exciter housing.

